

FRESA LIVELLATRICE

EL 50-75-100 R
EL 50-75-100 SH

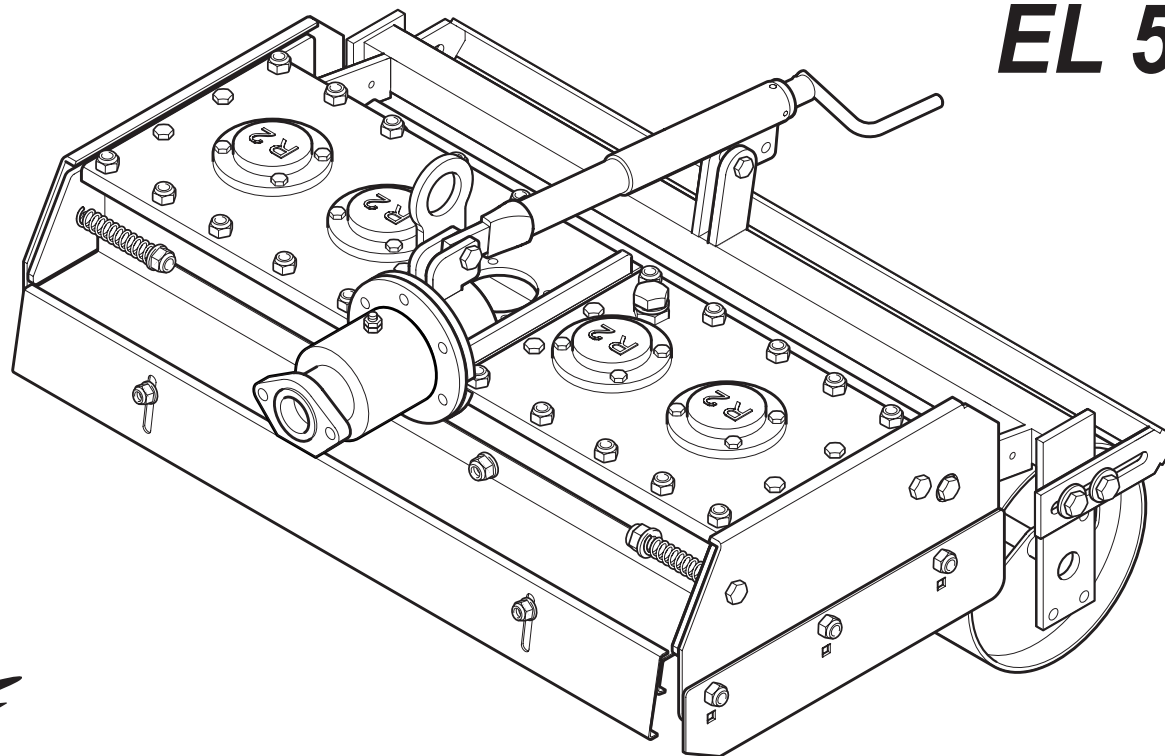

R2 Rinaldi Srl

40024 Castel San Pietro Terme (BO) Italy - via degli Artigiani, 23
Tel. +39.051.943042 • Fax +39.051.6942086 • e-mail: r2@r2rinaldi.com

CATALOGO PARTI DI RICAMBIO

SPARE PARTS CATALOGUE
CATALOGUE DE PIECES DETACHEES
ERSATZTEILKATALOG
CATALOGO DE PIEZAS DE REPUESTO

Cod. **039** rev.0

Edizione 03/2019

SIMBOLOGIA • SYMBOLS • SYMBOLES UTILISES • SYMBOLE • SIMBOLOGIA

I

Nella colonna CODICE di ogni distinta può essere presente uno di questi simboli:



Parte di ricambio momentaneamente priva di codice.

Per identificarla occorre indicare:

- Numero della tavola
- Numero di posizione
- Modello e matricola della macchina.

GB

In the CODED column of each list, you find one of following symbols:



Spare part temporarily uncoded.

To identify the part you must specify:

- Table code
- Position number
- Machine model and serial number.

F

Dans la colonne CODE de chaque liste Vous pouvez trouver un des symboles suivants:



Pièce de réchange temporairement sans code.

Pour son identification, il faut spécifier:

- Code du tableau
- Numéro de position
- Modèle et numéro de fabrique machine.

D

Die Reihe Anmerkungen jeder CODE kann ein folgender Symbole zeigen:



Ersatzteil hat vorübergehend keinen Code.

Um diesen Ersatzteil angeben zu können, müssen Sie:

- Code Tabelle
- Positionsnummer
- Maschinenmodell und -nummer.

E

La columna CÓDIGO de cada lista puede presentar uno de los símbolos siguientes:



Repuesto actualmente falto de código.

Para la identificación del repuesto es necesario indicar:

- Código tabla
- Número de posición
- Modelo y número de serie máquina.



Parte di ricambio avente ulteriori parti di ricambio interne.

Per identificare le singole parti interne occorre andare alla tavola di corrispondente denominazione.



Spare part consisting of more internal spare parts.

To find the single internal parts, please refer to the relevant description table.



Pièce de réchange comprenant des pièces de rechange à l'intérieur.

Pour l'identification de pièces individuelles, se référer au tableau descriptif correspondant.



Ersatzteil hat weitere Ersatzteile auf der Innenseite.

Für die Identifikation der einzelnen Innerteile, die entsprechende Benennungstabelle nachschlagen.



Ruesto que consta de sucesivos repuestos internos.

Para la identificación de las partes internas distintas, ver tabla descriptiva correspondiente.



Parte di ricambio con variabili dimensionali o di quantità.

Occorre specificare il modello e la matricola della macchina individuali nell'apposita targhetta.



Spare part with dimension or quantity variables.

Always specify the machine model and serial number, given in the identification plate.



Pièce détachée avec variables dimensionnelles o de quantité.

Spécifier toujours le modèle et le numéro de fabrique de la machine, donnés sur la plaque d'identification.



Ersatzteil mit variablen Maßen oder Menge.

Bitte, Modell und Fabriknummer der Maschine, die auf dem Typenschild abgedruckt sind, angeben.



Repuesto con variables dimensionales o de cantidad.

Declarar siempre el modelo y el número de serie de la máquina, que se encuentran en la tarjeta de identificación.

COME ORDINARE I RICAMBI • HOW TO ORDER SPARE PARTS • COMMANDE DES PIÈCES DÉTACHÉES • ANFRANGE VON ERSATZTEILEN • PEDIDO DE LOS REPUESTOS

Per ordinare le parti di ricambio Vi preghiamo cortesemente di fornire al Servizio Assistenza tutte le seguenti informazioni:

- Modello, tipo e numero di matricola della macchina.
- Codice, descrizione e quantità delle parti di ricambio che si intendono ordinare.

Inoltre all'ordine sarà necessario precisare:

- Ragione sociale, indirizzo completo, recapito telefonico e telefax.
- Indirizzo completo al quale spedire le parti di ricambio.
- Eventuale mezzo di trasporto/vettore da utilizzare preferenzialmente.

When ordering spare parts, please supply After Sales Service the following information:

- Machine model, type and serial number
- Code, description and quantity of the spare parts you wish to order.

In addition to what above, add also:

- Corporate name, address, phone and fax number.
- Delivery address.
- Preferential transport mean/carrier.

Pour commander les pièces de rechange nous vous prions de bien vouloir transmettre au ServiceAprès-Vente les indications suivantes:

- Modèle, type et numéro de série de la machine.
- Code, description et quantité des pièces de rechange commandées.

De plus, indiquer dans la commande:

- Nom de la société, adresse complète, numéro de téléphone et de télécopieur.
- Adresse complète pour l'expédition.
- Eventuel moyen de transport/expéditeur préférentiel.

Um Ersatzteil zu bestellen, bitten wir Sie höflichst, dem Kundendienst alle nachfolgend angeführten Angaben zu machen:

- Modell, Typ und Matrikel-Nr. der Maschine.
- Code, Beschreibung und Anzahl der Ersatzteile, die man bestellen möchte.

Außerdem sollte man bei der Bestellung angeben:

- Name der Firma, vollständige Adresse, Telefon und Faxnummer.
- Vollständige Adresse, an die Ersatzteile zu senden sind.
- Von Ihnen gewünschtes Transportmittel / Transportunternehmen.

Para el pedido de repuestos, Le rogamos se sirvan suministrar al Servicio Asistencia todas las indicaciones siguientes:

- Modelo, tipo y número de matrícula de la máquina.
- Código, descripción y cantidad de los repuestos pedido.

Además, se ruega detallar lo siguiente:

- Razón social, dirección completa, teléfono y telefax.
- Dirección completa a la que se deben enviar los repuestos.
- Eventual medio/agente de transporte que se desea utilizar.

**ELENCO CODICI PARTICOLARI COSTRUTTIVI • COMPONENT CODE LIST • LISTE CODES COMPOSANTS
LISTE DER BAUTEILECODES • LISTA CÓDIGOS COMPONENTES**

Codice/Code	Tavola/Table
000.002	02.0 08.0
000.010	02.0 08.0
000.011	01.0 07.0
000.021	02.0 08.0
000.031	01.0 07.0
000.068	01.0 07.0
000.078	03.0
031.041	02.0 08.0
037.059	01.0
037.059P	05.0
039.001	02.0 08.0
039.002	02.0 08.0
039.003	02.0 08.0
039.004	02.0 08.0
039.005	02.0 08.0
039.006	02.0 08.0
039.007	02.0 08.0
039.010	01.0 05.0
039.015	02.0 08.0
039.016	02.0 08.0
039.017	02.0 08.0
039.018	01.0 07.0
039.019	02.0 08.0
039.020	01.0 07.0
039.021	01.0 07.0
039.022	01.0 07.0
039.026	04.0 06.0 07.0
039.028	04.0 06.0 07.0
039.032	06.0 07.0

Codice/Code	Tavola/Table
039.035	02.0 08.0
039.036	01.0 05.0
039.039	07.0
039.040	06.0 07.0
039.042	06.0 07.0
039.043	06.0 07.0
039.044	04.0
039.045	01.0 05.0
039.046	01.0 05.0
039.047	07.0
039.052	01.0 07.0
039.055	03.0
039.056	01.0 03.0
039.060	07.0
039.062	06.0 07.0
039.063	06.0 07.0
039.065	01.0
039.067	01.0
039.068	01.0
039.069	01.0 03.0
039.071	01.0 07.0
039.074	07.0
039.077	01.0 05.0
039.078	01.0 03.0
039.081	01.0 07.0
039.084	03.0
039.085	03.0
039.087	03.0
039.088	03.0

Codice/Code	Tavola/Table
050.001	01.0 07.0
050.253	01.0 07.0
071.010	06.0 07.0
071.035	01.0 04.0 05.0 06.0 07.0
071.060	06.0
071.210	01.0
071.210P	05.0

EL 50-75-100 R

versione con ruspetta e rullo standard
version with levelling bar and standard roller
version avec barre niveleuse et rouleau standard
version mit planierstange und serienmässiger walze
versión con barra niveladora y rodillo estándar





GRUPPO TELAIO E RULLO (EL 50-75-100 R)
FRAME AND ROLLER GROUP (EL 50-75-100 R)
GROUPE CHASSIS ET ROULEAU (EL 50-75-100 R)
GRUPPE RAHMEN UND WALZEN (EL 50-75-100 R)
GRUPO BASTIDOR Y RODILLO (EL 50-75-100 R)

EL 50-75-100 R

Tav. 01.0

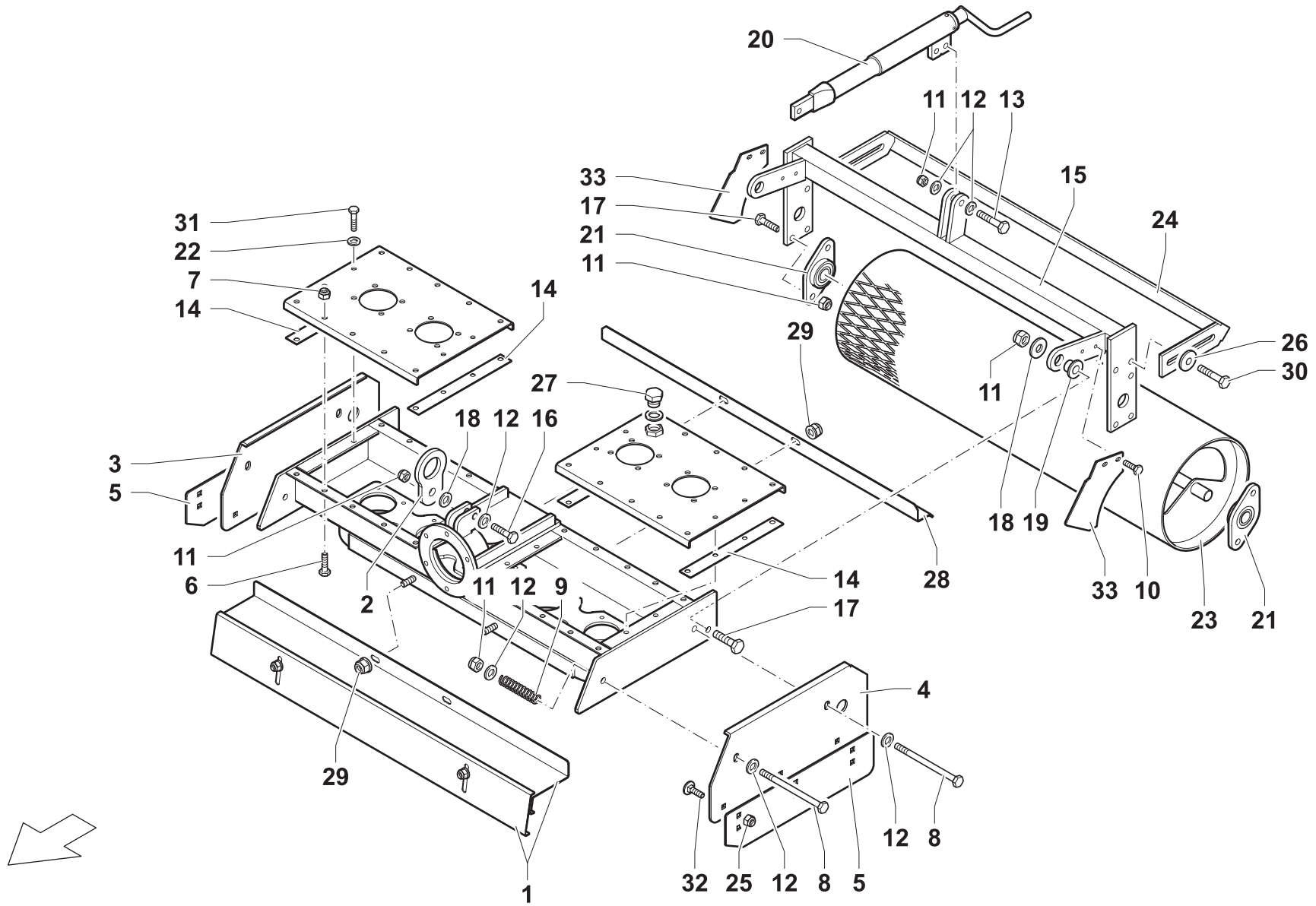

<i>Rif.</i>	<i>CODICE</i>	<i>Qty</i>	<i>Descrizione</i>	<i>Description</i>	<i>Designation</i>	<i>Benennung</i>	<i>Denominaciones</i>
1	039.052	1	PROTEZIONE ANTERIORE EL50	FRONT GUARD	PROTECTION AVANT	VORDERE SCHUTZABDECKUNG	PROTECCIÓN ANTERIOR
1	039.081	1	PROTEZIONE ANTERIORE EL75	FRONT GUARD	PROTECTION AVANT	VORDERE SCHUTZABDECKUNG	PROTECCIÓN ANTERIOR
1	039.071	1	PROTEZIONE ANTERIORE EL100	FRONT GUARD	PROTECTION AVANT	VORDERE SCHUTZABDECKUNG	PROTECCIÓN ANTERIOR
2	000.031	1	ANELLO DI SOLLEVAMENTO	EYEBOLT	ANNEAU DE LEVAGE	AUGENSCHRAUBE	ARMELLA
3	039.020	1	FIANCHETTO DX	RIGHT SIDE	COTE DROIT	SEITENWAND RECHTS	CÀRTER DERECHO
4	039.021	1	FIANCHETTO SX	LEFT SIDE	COTE GAUCHE	SEITENWAND LINKS	CÀRTER IZQUIERDO
5	039.022	2	PROLUNGA	EXTENSION	RALLONGE	VERLÄNGERUNG	PROLONGA
6	21.0.1.08016	20	VITE	SCREW	VIS	SCHRAUBE	TORNILLO
7	30.01.00.008	20	DADO AUTOBLOCCANTE	STOP NUT	ECROU DE SURETE	SPERRMUTTER	TUERCA AUTOTRABADORA
8	20.0.0.10100	4	VITE	SCREW	VIS	SCHRAUBE	TORNILLO
9	000.011	4	MOLLA	SPRING	RESSORT	FEDER	RESORTE
10	50.0.0.06012	4	VITE	SCREW	VIS	SCHRAUBE	TORNILLO
11	30.03.00.010	12	DADO AUTOBLOCCANTE	STOP NUT	ECROU DE SURETE	SPERRMUTTER	TUERCA AUTOTRABADORA
12	15.0.0.00.010	11	RONDELLA PIANA	FLAT WASHER	RONDELLE PLANE	FLACHSCHEIBE	ARANDELA LLANA
13	20.0.0.10045	1	VITE	SCREW	VIS	SCHRAUBE	TORNILLO
14	039.018	4	GUARNIZIONE	PACKING	JOINT	DICHTUNG	GUARNICIÓN
15	039.045	1	SUPPORTO RULLO EL50	SUPPORT	SUPPORT	LAGER	SOPORTE
15	039.036	1	SUPPORTO RULLO EL75	SUPPORT	SUPPORT	LAGER	SOPORTE
15	039.067	1	SUPPORTO RULLO EL100	SUPPORT	SUPPORT	LAGER	SOPORTE
16	20.0.0.10050	1	VITE	SCREW	VIS	SCHRAUBE	TORNILLO
17	20.0.0.10035	6	VITE	SCREW	VIS	SCHRAUBE	TORNILLO
18	15.1.0.00.010	3	RONDELLA	WASHER	RONDELLE	SCHEIBE	ARANDELA
19	071.035	2	BOCCOLA SUPPORTO RULLO	ROLLER BUSHING	COUSSINET ROULEAU	BUCHSE WALZE	CONJINETE RODILLO
20	000.068	1	REGISTRO	ADJUSTER	REGLAGE	REGULATOR	AJUSTE
21	61.00.00204	2	SUPPORTO	SUPPORT	SUPPORT	LAGER	SOPORTE
22	15.2.1.00.008	8	RONDELLA DENTELLATA	SERRATED WASHER	RONDELLE EVENTAIL	FÄCHERSCHEIBE	ARANDELA ABANICO
23	037.059	1	RULLO EL50	ROLLER	ROULEAU	WALZE ROLLE	RODILLO
23	071.210	1	RULLO EL75	ROLLER	ROULEAU	WALZE ROLLE	RODILLO
23	039.065	1	RULLO EL100	ROLLER	ROULEAU	WALZE ROLLE	RODILLO
24	039.046	1	PULISCI RULLO EL50	ROLLER CLEANER	NETTOYEUR ROULEAU	WALZENREINIGER	LIMPIADOR RODILLO
24	039.010	1	PULISCI RULLO EL75	ROLLER CLEANER	NETTOYEUR ROULEAU	WALZENREINIGER	LIMPIADOR RODILLO



EL 50-75-100 R

Tav. 01.0



GRUPPO TELAIO E RULLO (EL 50-75-100 R)
FRAME AND ROLLER GROUP (EL 50-75-100 R)
GROUPE CHASSIS ET ROULEAU (EL 50-75-100 R)
GRUPPE RAHMEN UND WALZEN (EL 50-75-100 R)
GRUPO BASTIDOR Y RODILLO (EL 50-75-100 R)

EL 50-75-100 R

Tav. 01.0

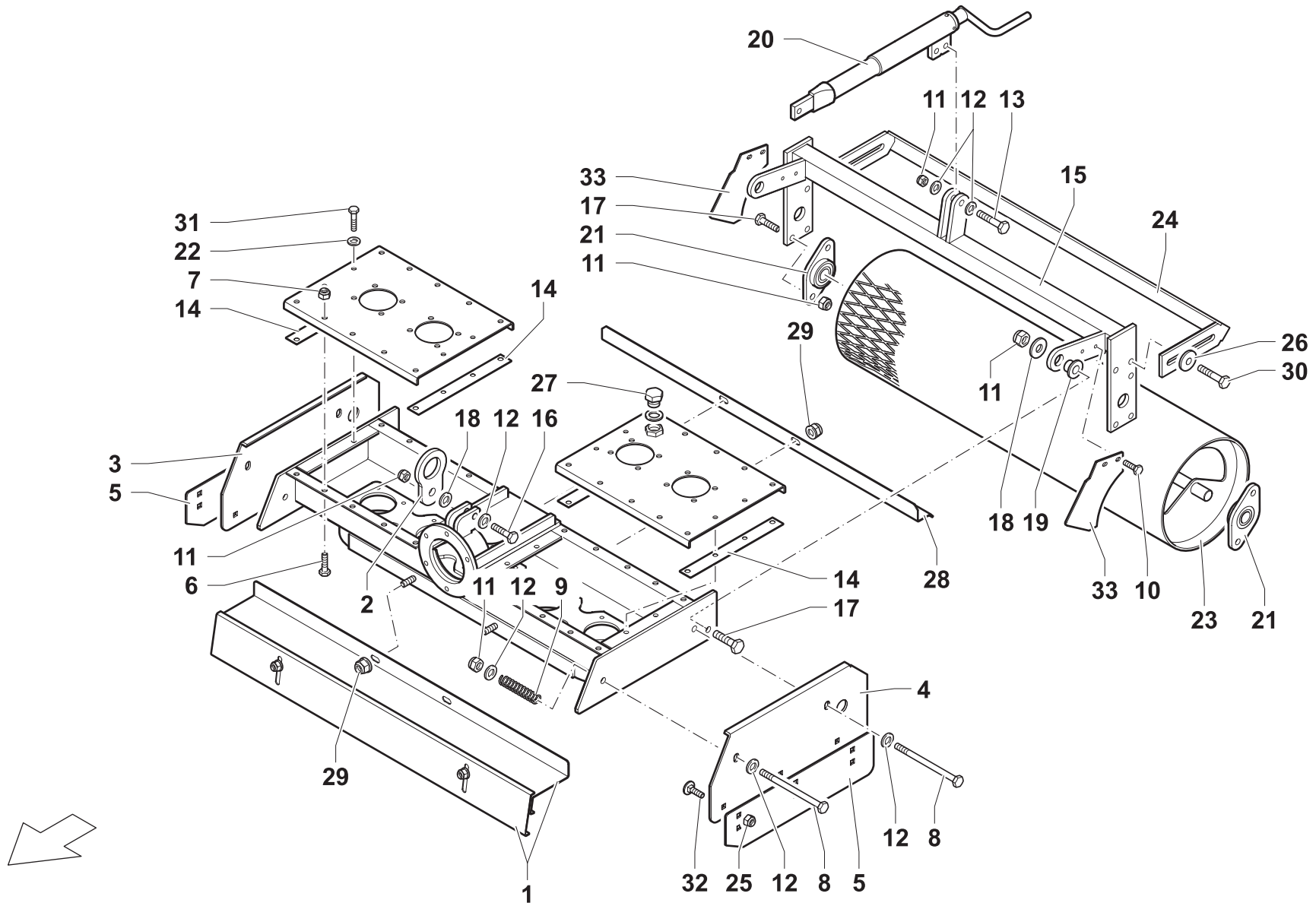

<i>Rif.</i>	<i>CODICE</i>	<i>Qnt</i>	<i>Descrizione</i>	<i>Description</i>	<i>Designation</i>	<i>Benennung</i>	<i>Denominaciones</i>
24	039.068	1	PULISCI RULLO EL100	ROLLER CLEANER	NETTOYEUR ROULEAU	WALZENREINIGER	LIMPIADOR RODILLO
25	30.01.00.008	6	DADO AUTOBLOCCANTE	STOP NUT	ECROU DE SURETE	SPERRMUTTER	TUERCA AUTOTRABADORA
26	15.1.0.00.008	4	RONDELLA	WASHER	RONDELLE	SCHEIBE	ARANDELA
27	050.001	1	TAPPO	CAP	BOUCHON	STOPFEN	TAPÓN
28	039.056	1	PROTEZIONE POSTERIORE EL50	REAR GUARD	PROTECTION ARRIÈRE	HINTERE SCHUTZABDECKUNG	PROTECCIÓN POSTERIOR
28	039.078	1	PROTEZIONE POSTERIORE EL75	REAR GUARD	PROTECTION ARRIÈRE	HINTERE SCHUTZABDECKUNG	PROTECCIÓN POSTERIOR
28	039.069	1	PROTEZIONE POSTERIORE EL100	REAR GUARD	PROTECTION ARRIÈRE	HINTERE SCHUTZABDECKUNG	PROTECCIÓN POSTERIOR
29	32.02.00.0.08	4	DADO	NUT	ECROU	MUTTER	TUERCA
30	21.0.0.08016	4	VITE	SCREW	VIS	SCHRAUBE	TORNILLO
31	21.0.1.08020	8	VITE	SCREW	VIS	SCHRAUBE	TORNILLO
32	050.253	6	BULLONE	SCREW	VIS	SCHRAUBE	TORNILLO
33	039.077	2	PROTEZIONE LATERALE	SIDE GUARD	PROTECTION LATERALE	SEITLICHE SCHUTZABDECKUNG	PROTECCIÓN LATERAL



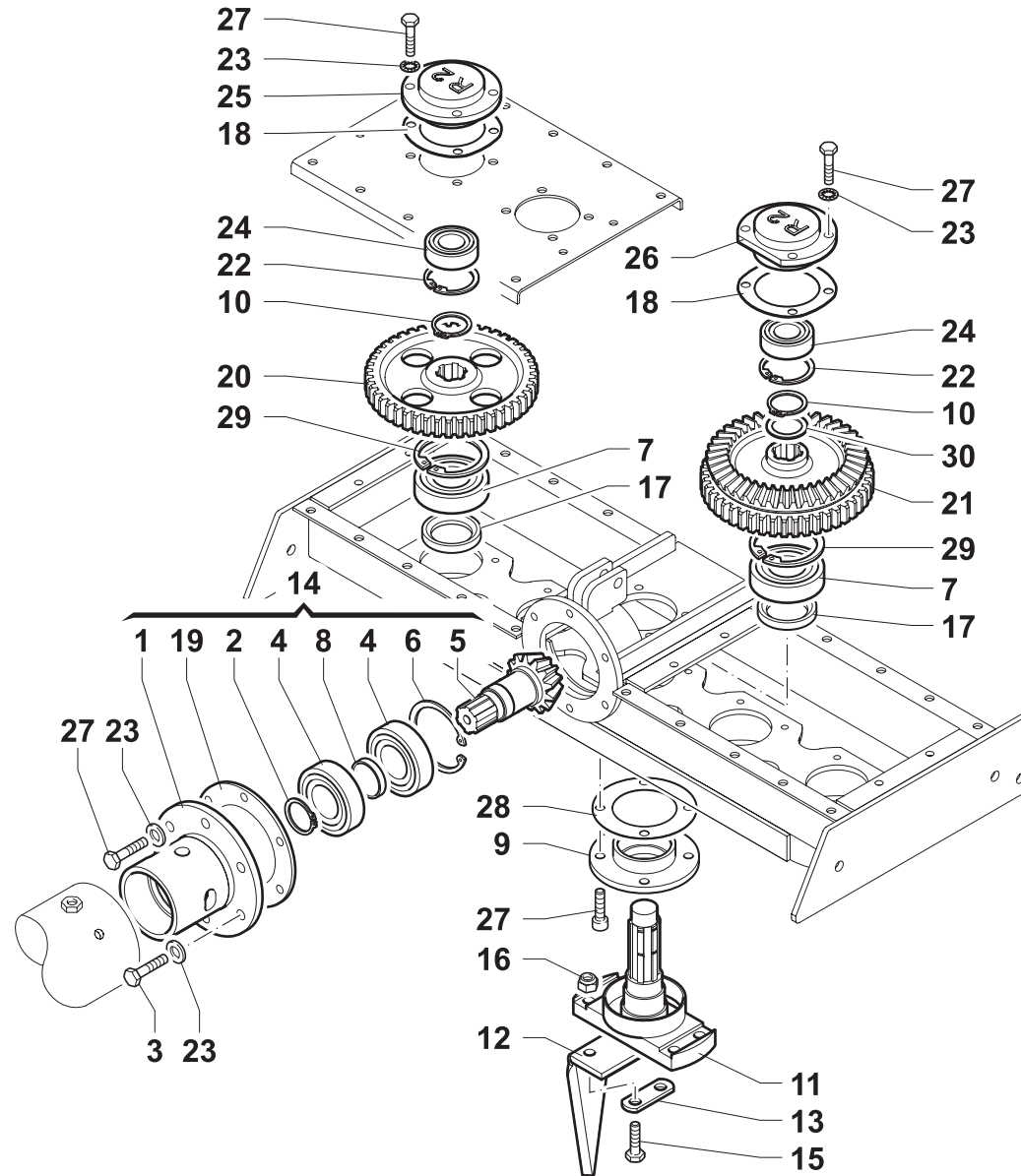

<i>Rif.</i>	<i>CODICE</i>	<i>Qnt</i>	<i>Descrizione</i>	<i>Description</i>	<i>Designation</i>	<i>Benennung</i>	<i>Denominaciones</i>
1	039.019	1	MOZZO	HUB	MOYEU	NABE	CUBO
2	18.01.01.030	1	SEEGER	RING	BAGUE	RING	ANILLO
3	21.0.0.08022	3	VITE	SCREW	VIS	SCHRAUBE	TORNILLO
4	60.02.06006	2	CUSCINETTO	BEARING	PALIER	KUGELLAGER	COJINETE
5	039.004	1	PIGNONE	SPROCKET	PIGNON	RITZEL	PINON
6	18.00.00.055	1	SEEGER	RING	BAGUE	RING	ANILLO
7	60.00.06205	5	CUSCINETTO	BEARING	PALIER	KUGELLAGER	COJINETE
8	031.041	1	DISTANZIALE	SPACER	ENTRETOISE	ABSTANDSHALTER	SEPARADOR
9	039.005	5	FLANGIA	FLANGE	BRIDE	FLANSCH	BRIDA
10	18.01.01.025	5	SEEGER	RING	BAGUE	RING	ANILLO
11	039.002	5	FORCELLA	FORK	FOURCHE	GABEL	HORQUILLA
12	000.021	6	DENTE EL50	TOOTH	DENT	ZAHN	DIENTE
12	000.010	10	DENTE	TOOTH	DENT	ZAHN	DIENTE
13	000.002	10	PIASTRINA	PLATE	PLAQUETTE	PLÄTTCHEN	PLACA
14	039.035	1	MOZZO PIGNONE COMPLETO	COMPLETE HUB WITH SPROCKET	MOYEU COMPLET AVEC PIGNON	KOMPLLETTE NABE MIT ZAHNRAD	CUBO COMPLETO CON PIÑÓN
15	20.1.1.10035	20	VITE	SCREW	VIS	SCHRAUBE	TORNILLO
16	30.03.01.010	20	DADO AUTOBLOCCANTE	STOP NUT	ECROU DE SURETE	SPERRMUTTER	TUERCA AUTOTRABADORA
17	70.1.030477	5	ANELLO TENUTA	SEAL	GARNITURE	DICHTRING	GUARNICIÓN
18	039.015	5	GUARNIZIONE	PACKING	JOINT	DICHTUNG	GUARNICIÓN
19	039.017	1	GUARNIZIONE	PACKING	JOINT	DICHTUNG	GUARNICIÓN
20	039.001	4	INGRANAGGIO	GEAR	ENGRENAGE	ZAHNRADGETRIEBE	ENGRANAJE
21	039.003	1	CORONA	RING GEAR	COURONNE	KRANZ	CORONA
22	18.00.00.042	5	SEEGER	RING	BAGUE	RING	ANILLO
23	15.2.1.00.008	26	RONDELLA DENTELLATA	SERRATED WASHER	RONDELLE EVENTAIL	FÄCHERSCHEIBE	ARANDELA ABANICO
24	60.02.06004	5	CUSCINETTO	BEARING	PALIER	KUGELLAGER	COJINETE
25	039.007	4	COPERCHIETTO LATERALE	SIDE COVER	COUVERCLE LATÉRÀL	KLEINER SEITL. DECKEL	TAPA LATERAL
26	039.006	1	COPERCHIETTO CENTRALE	CENTRAL COVER	COUVERCLE CENTRALE	KLEINER ZENTRALER DECKEL	TAPA CENTRAL
27	21.0.1.08020	43	VITE	SCREW	VIS	SCHRAUBE	TORNILLO
28	039.016	5	GUARNIZIONE	PACKING	JOINT	DICHTUNG	GUARNICIÓN
29	18.00.00.052	5	SEEGER	RING	BAGUE	RING	ANILLO
30	09.050.25035	1	RONDELLA	WASHER	RONDELLE	SCHEIBE	ARANDELA



EL 50-75-100 R

Tav. 02.0



RUSPETTA (EL 50-75-100 R)
LEVELLING BAR (EL 50-75-100 R)
BARRE NIVELEUSE (EL 50-75-100 R)
PLANIERSTANGE (EL 50-75-100 R)
BARRA NIVELADORA (EL 50-75-100 R)

EL 50-75-100 R

Tav. 03.0

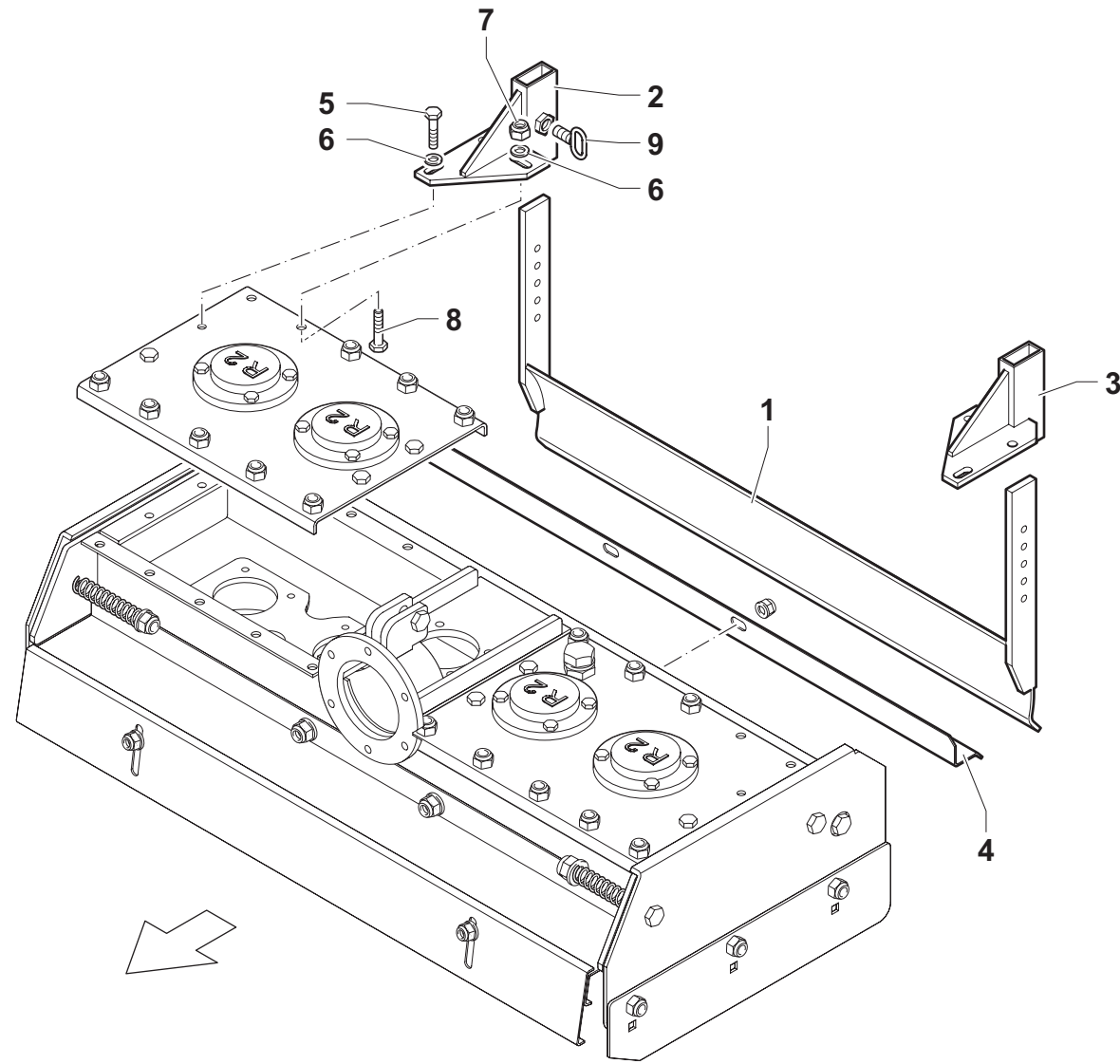

<i>Rif.</i>	<i>CODICE</i>	<i>Qty</i>	<i>Descrizione</i>	<i>Description</i>	<i>Designation</i>	<i>Benennung</i>	<i>Denominaciones</i>
1	039.055	1	RUSPETTA EL50	LEVELLING BAR	BARRE NIVELEUSE	PLANIERSTANGE	BARRA NIVELADORA
1	039.087	1	RUSPETTA EL75	LEVELLING BAR	BARRE NIVELEUSE	PLANIERSTANGE	BARRA NIVELADORA
1	039.088	1	RUSPETTA EL100	LEVELLING BAR	BARRE NIVELEUSE	PLANIERSTANGE	BARRA NIVELADORA
2	039.084	1	SUPPORTO DESTRO	RIGHT SUPPORT	SUPPORT DROIT	LAGER RECHTS	SOPORTE DERECHO
3	039.085	1	SUPPORTO SINISTRO	LEFT SUPPORT	SUPPORT GAUCHE	LAGER LINKS	SOPORTE IZQUIERDO
4	039.056	1	PROTEZIONE POSTERIORE EL50	REAR GUARD	PROTECTION ARRIÈRE	HINTERE SCHUTZABDECKUNG	PROTECCIÓN POSTERIOR
4	039.078	1	PROTEZIONE POSTERIORE EL75	REAR GUARD	PROTECTION ARRIÈRE	HINTERE SCHUTZABDECKUNG	PROTECCIÓN POSTERIOR
4	039.069	1	PROTEZIONE POSTERIORE EL100	REAR GUARD	PROTECTION ARRIÈRE	HINTERE SCHUTZABDECKUNG	PROTECCIÓN POSTERIOR
5	21.0.0.08020	2	VITE	SCREW	VIS	SCHRAUBE	TORNILLO
6	15.0.0.00.008	6	RONDELLA DENTELLATA	SERRATED WASHER	RONDELLE EVENTAIL	FÄCHERSCHEIBE	ARANDELA ABANICO
7	30.01.00.008	4	DADO AUTOBLOCCANTE	STOP NUT	ECROU DE SURETE	SPERRMUTTER	TUERCA AUTOTRABADORA
8	21.0.0.08022	4	VITE	SCREW	VIS	SCHRAUBE	TORNILLO
9	000.078	2	FRULLETTO	THREADED PIN	AXE TARAUDE	GEWINDEBOLZEN	PERNO CON ROSCA





KIT RULLO A GABBIA (EL75)
CAGE ROLLER KIT (EL75)
KIT ROULEAU A CAGE (EL75)
KAFIGWALZENKIT (EL75)
KIT RODILLO A JAULA (EL75)

EL 50-75-100 R

Tav. 04.0

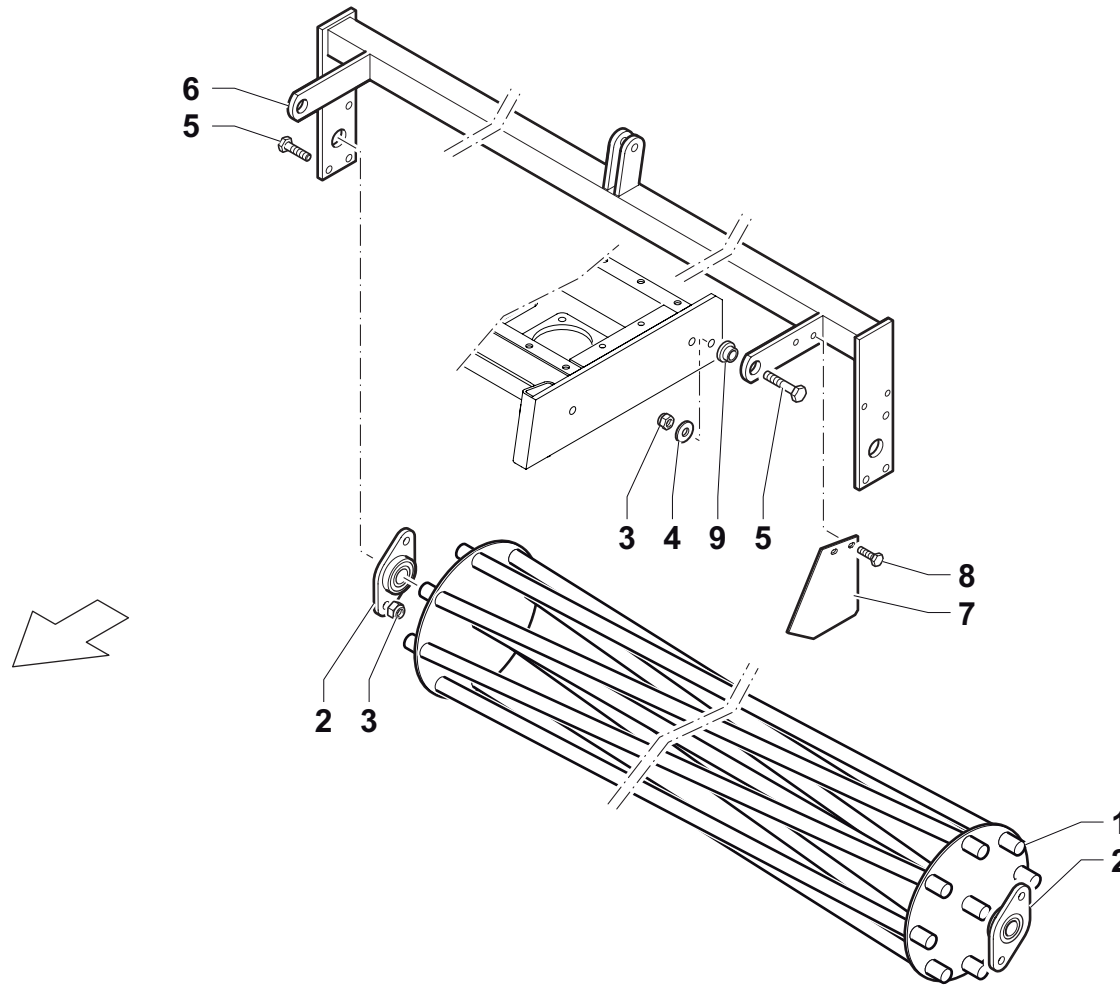

Rif.	CODICE	Qty	Descrizione	Description	Designation	Benennung	Denominaciones
1	039.044	1	RULLO EL75	ROLLER	ROULEAU	WALZE ROLLE	RODILLO
2	61.00.00204	2	SUPPORTO	SUPPORT	SUPPORT	LAGER	SOPORTE
3	30.03.00.010	6	DADO AUTOBLOCCANTE	STOP NUT	ECROU DE SURETE	SPERRMUTTER	TUERCA AUTOTRABADORA
4	15.1.0.00.010	2	RONDELLA	WASHER	RONDELLE	SCHEIBE	ARANDELA
5	20.0.0.10035	6	VITE	SCREW	VIS	SCHRAUBE	TORNILLO
6	039.028	1	SUPPORTO RULLO EL75	SERRATED WASHER	RONDELLE EVENTAIL	FÄCHERSCHEIBE	ARANDELA ABANICO
7	039.026	1	PROTEZIONE RULLO	ROLLER PROTECTION	PROTECTION ROULEAU	SCHUTZABDECKUNG WALZE	PROTECCIÓN RODILLO
8	50.0.0.06012	4	VITE	SCREW	VIS	SCHRAUBE	TORNILLO
9	071.035	2	BOCCOLA	BUSHING	DOUILLE	BÜCHSE	CASQUILLO





KIT RULLO PIENO (EL 50-75)
PLAIN ROLLER KIT (EL 50-75)
KIT ROULEAU PLEIN (EL 50-75)
WOLLWALZENKIT (EL 50-75)
KIT RODILLO LLANO (EL 50-75)

EL 50-75-100 R

Tav. 05.0

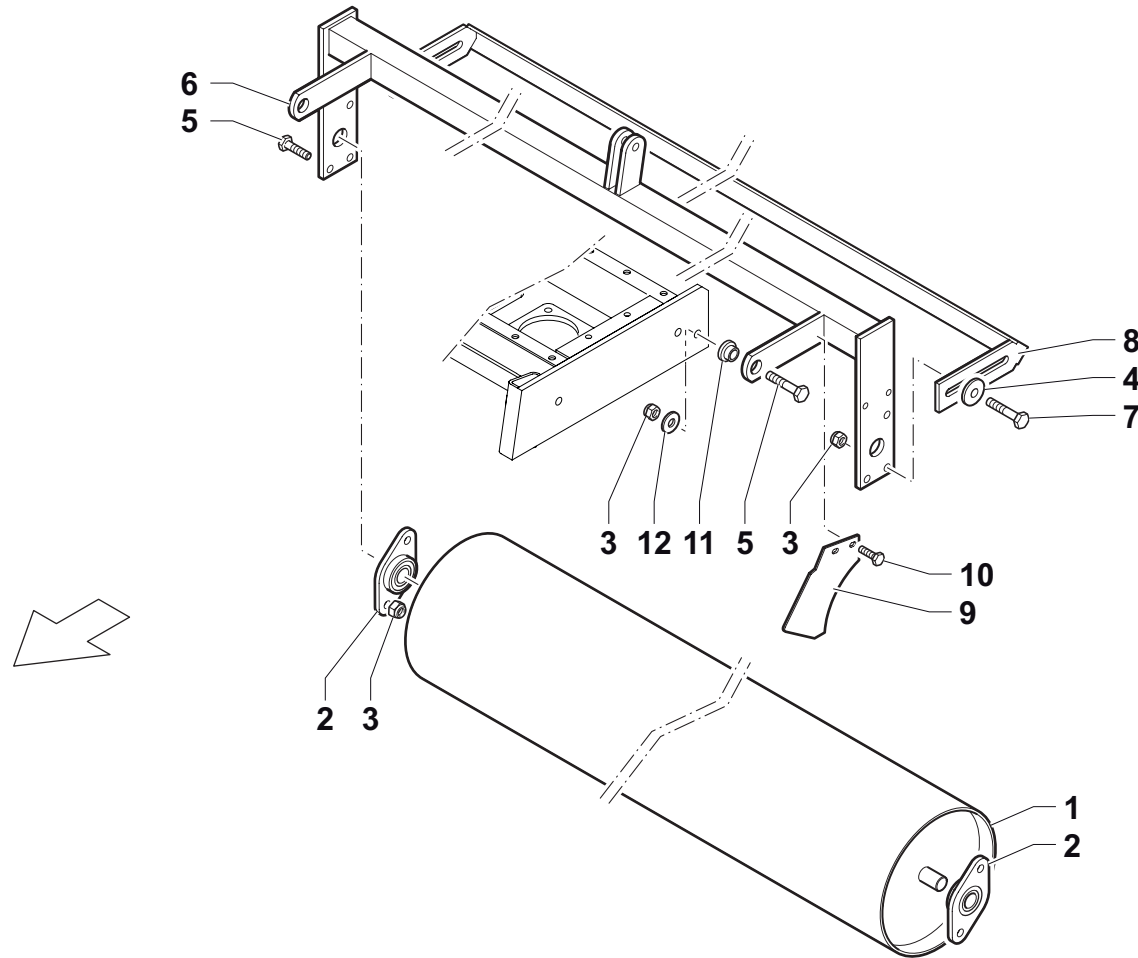

Rif.	CODICE	Qty	Descrizione	Description	Designation	Benennung	Denominaciones
1	037.059P	1	RULLO EL50	ROLLER	ROULEAU	WALZE ROLLE	RODILLO
1	071.210P	1	RULLO EL75	ROLLER	ROULEAU	WALZE ROLLE	RODILLO
2	61.00.00204	2	SUPPORTO	SUPPORT	SUPPORT	LAGER	SOPORTE
3	30.03.00.010	6	DADO AUTOBLOCCANTE	STOP NUT	ECROU DE SURETE	SPERRMUTTER	TUERCA AUTOTRABADORA
4	15.1.0.00.008	4	RONDELLA	WASHER	RONDELLE	SCHEIBE	ARANDELA
5	20.0.0.10035	6	VITE	SCREW	VIS	SCHRAUBE	TORNILLO
6	039.045	1	SUPPORTO RULLO EL50	SERRATED WASHER	RONDELLE EVENTAIL	FÄCHERSCHEIBE	ARANDELA ABANICO
6	039.036	1	SUPPORTO RULLO EL75	SERRATED WASHER	RONDELLE EVENTAIL	FÄCHERSCHEIBE	ARANDELA ABANICO
7	21.0.0.08016	2	VITE	SCREW	VIS	SCHRAUBE	TORNILLO
8	039.046	1	PULISCI RULLO EL50	ROLLER CLEANER	NETTOYEUR ROULEAU	WALZENREINIGER	LIMPIADOR RODILLO
8	039.010	1	PULISCI RULLO EL75	ROLLER CLEANER	NETTOYEUR ROULEAU	WALZENREINIGER	LIMPIADOR RODILLO
9	039.077	1	PROTEZIONE RULLO	ROLLER PROTECTION	PROTECTION ROULEAU	SCHUTZABDECKUNG WALZE	PROTECCIÓN RODILLO
10	50.0.0.06012	4	VITE	SCREW	VIS	SCHRAUBE	TORNILLO
11	071.035	2	BOCCOLA	BUSHING	DOUILLE	BÜCHSE	CASQUILLO
12	15.1.0.00.010	2	RONDELLA	WASHER	RONDELLE	SCHEIBE	ARANDELA





KIT RULLO CORTO (EL 50-75-100)
SHORT ROLLER KIT (EL 50-75-100)
KIT ROULEAU COURT (EL 50-75-100)
KIT KURZE WALZE (EL 50-75-100)
KIT RODILLO CORTO (EL 50-75-100)

EL 50-75-100 R

Tav. 06.0

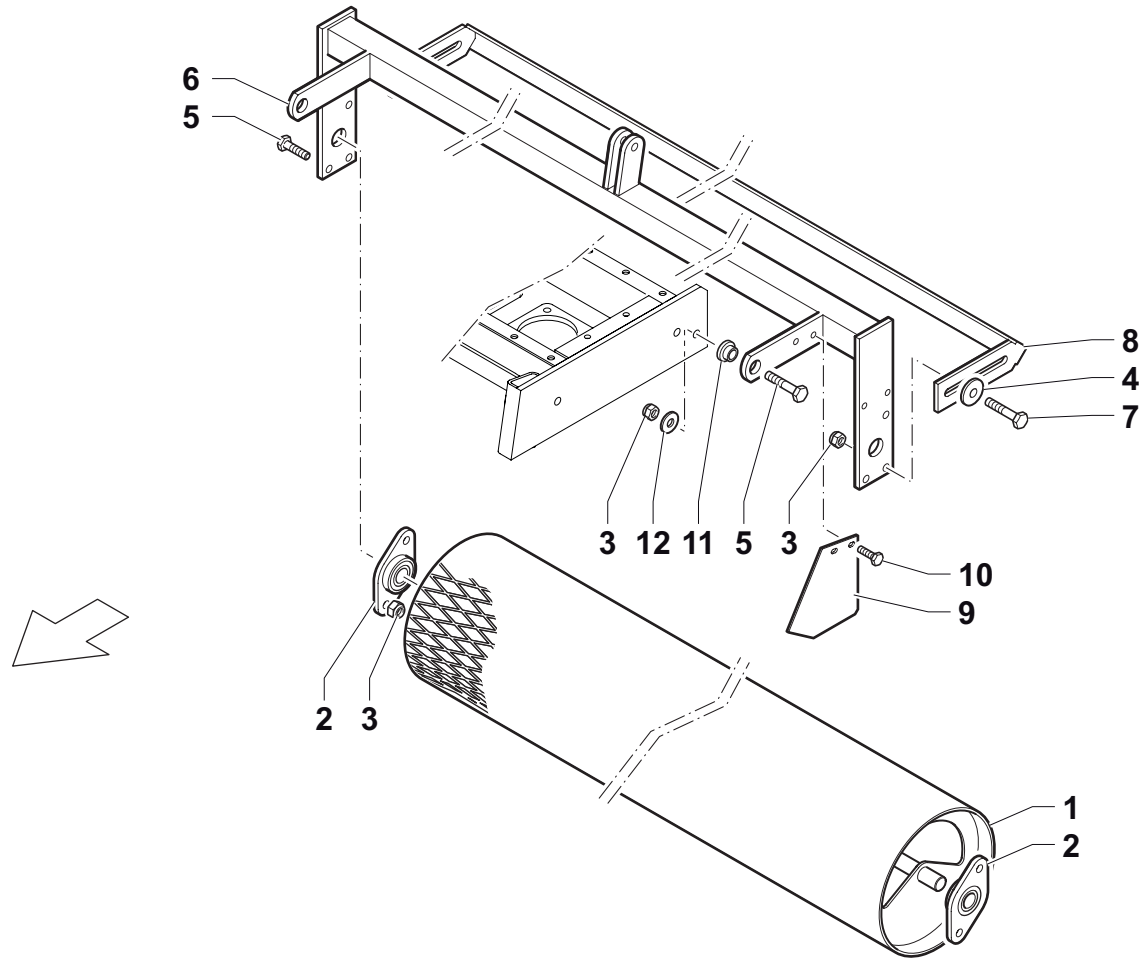

<i>Rif.</i>	<i>CODICE</i>	<i>Qty</i>	<i>Descrizione</i>	<i>Description</i>	<i>Designation</i>	<i>Benennung</i>	<i>Denominaciones</i>
1	039.040	1	RULLO EL50	ROLLER	ROULEAU	WALZE ROLLE	RODILLO
1	071.010	1	RULLO EL75	ROLLER	ROULEAU	WALZE ROLLE	RODILLO
1	039.060	1	RULLO EL100	ROLLER	ROULEAU	WALZE ROLLE	RODILLO
2	61.00.00204	2	SUPPORTO	SUPPORT	SUPPORT	LAGER	SOPORTE
3	30.03.00.010	6	DADO AUTOBLOCCANTE	STOP NUT	ECROU DE SURETE	SPERRMUTTER	TUERCA AUTOTRABADORA
4	15.1.0.00.008	4	RONDELLA	WASHER	RONDELLE	SCHEIBE	ARANDELA
5	20.0.0.10035	6	VITE	SCREW	VIS	SCHRAUBE	TORNILLO
6	039.042	1	SUPPORTO RULLO EL50	SERRATED WASHER	RONDELLE EVENTAIL	FÄCHERSCHEIBE	ARANDELA ABANICO
6	039.028	1	SUPPORTO RULLO EL75	SERRATED WASHER	RONDELLE EVENTAIL	FÄCHERSCHEIBE	ARANDELA ABANICO
6	039.062	1	SUPPORTO RULLO EL100	SERRATED WASHER	RONDELLE EVENTAIL	FÄCHERSCHEIBE	ARANDELA ABANICO
7	21.0.0.08016	4	VITE	SCREW	VIS	SCHRAUBE	TORNILLO
8	039.043	1	PULISCI RULLO EL50	ROLLER CLEANER	NETTOYEUR ROULEAU	WALZENREINIGER	LIMPIADOR RODILLO
8	039.032	1	PULISCI RULLO EL75	ROLLER CLEANER	NETTOYEUR ROULEAU	WALZENREINIGER	LIMPIADOR RODILLO
8	039.063	1	PULISCI RULLO EL100	ROLLER CLEANER	NETTOYEUR ROULEAU	WALZENREINIGER	LIMPIADOR RODILLO
9	039.026	2	PROTEZIONE RULLO	ROLLER PROTECTION	PROTECTION ROULEAU	SCHUTZABDECKUNG WALZE	PROTECCIÓN RODILLO
10	50.0.0.06012	4	VITE	SCREW	VIS	SCHRAUBE	TORNILLO
11	071.035	2	BOCCOLA	BUSHING	DOUILLE	BÜCHSE	CASQUILLO
12	15.1.0.00.010	2	RONDELLA	WASHER	RONDELLE	SCHEIBE	ARANDELA



Pagina lasciata intenzionalmente bianca
This page intentionally left blank
Page laissée blanche intentionnellement
Diese Seite wurde absichtlich leer gelassen
Página dejada en blanco intencionalmente

EL 50-75-100 SH

versione senza ruspetta e con rullo corto
version without levelling bar with short roller
version sans barre niveleuse avec rouleau court
version ohne planierstange mit kurzer walze
versión sin barra niveladora con rodillo corto





GRUPPO TELAIO E RULLO (EL 50-75-100 SH)
FRAME AND ROLLER GROUP (EL 50-75-100 SH)
GROUPE CHASSIS ET ROULEAU (EL 50-75-100 SH)
GRUPPE RAHMEN UND WALZEN (EL 50-75-100 SH)
GRUPO BASTIDOR Y RODILLO (EL 50-75-100 SH)

EL 50-75-100 SH

Tav. 07.0

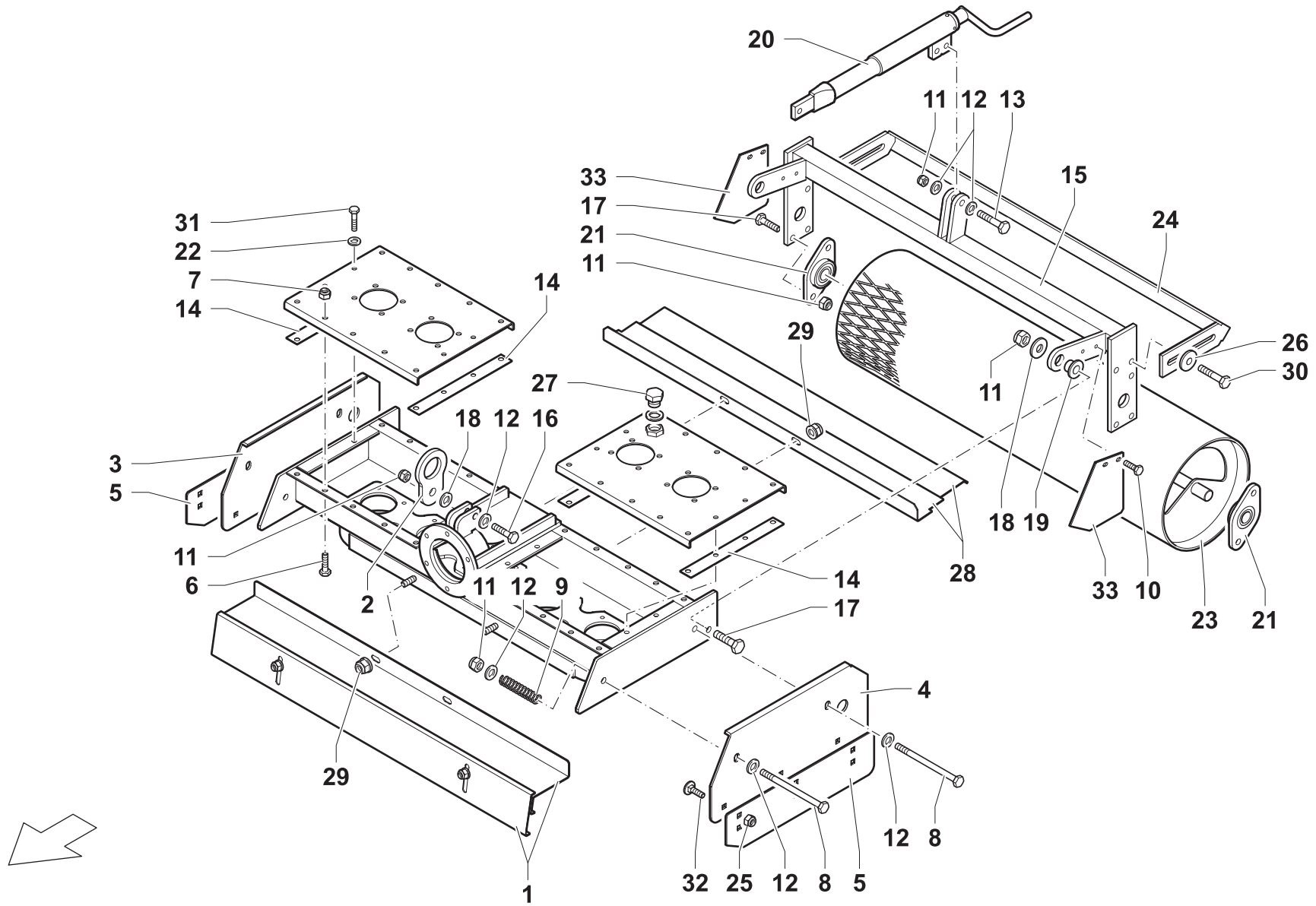

<i>Rif.</i>	<i>CODICE</i>	<i>Qnt</i>	<i>Descrizione</i>	<i>Description</i>	<i>Designation</i>	<i>Benennung</i>	<i>Denominaciones</i>
1	039.052	1	PROTEZIONE ANTERIORE EL50	FRONT GUARD	PROTECTION AVANT	VORDERE SCHUTZABDECKUNG	PROTECCIÓN ANTERIOR
1	039.081	1	PROTEZIONE ANTERIORE EL75	FRONT GUARD	PROTECTION AVANT	VORDERE SCHUTZABDECKUNG	PROTECCIÓN ANTERIOR
1	039.071	1	PROTEZIONE ANTERIORE EL100	FRONT GUARD	PROTECTION AVANT	VORDERE SCHUTZABDECKUNG	PROTECCIÓN ANTERIOR
2	000.031	1	ANELLO DI SOLLEVAMENTO	EYEBOLT	ANNEAU DE LEVAGE	AUGENSCHRAUBE	ARMELLA
3	039.020	1	FIANCHETTO DX	RIGHT SIDE	COTE DROIT	SEITENWAND RECHTS	CÀRTER DERECHO
4	039.021	1	FIANCHETTO SX	LEFT SIDE	COTE GAUCHE	SEITENWAND LINKS	CÀRTER IZQUIERDO
5	039.022	2	PROLUNGA	EXTENSION	RALLONGE	VERLÄNGERUNG	PROLONGA
6	21.0.1.08016	20	VITE	SCREW	VIS	SCHRAUBE	TORNILLO
7	30.01.00.008	20	DADO AUTOBLOCCANTE	STOP NUT	ECROU DE SURETE	SPERRMUTTER	TUERCA AUTOTRABADORA
8	20.0.0.10100	4	VITE	SCREW	VIS	SCHRAUBE	TORNILLO
9	000.011	4	MOLLA	SPRING	RESSORT	FEDER	RESORTE
10	50.0.0.06012	4	VITE	SCREW	VIS	SCHRAUBE	TORNILLO
11	30.03.00.010	12	DADO AUTOBLOCCANTE	STOP NUT	ECROU DE SURETE	SPERRMUTTER	TUERCA AUTOTRABADORA
12	15.0.0.00.010	11	RONDELLA PIANA	FLAT WASHER	RONDELLE PLANE	FLACHSCHEIBE	ARANDELA LLANA
13	20.0.0.10045	1	VITE	SCREW	VIS	SCHRAUBE	TORNILLO
14	039.018	4	GUARNIZIONE	PACKING	JOINT	DICHTUNG	GUARNICIÓN
15	039.042	1	SUPPORTO RULLO EL50	SUPPORT	SUPPORT	LAGER	SOPORTE
15	039.028	1	SUPPORTO RULLO EL75	SUPPORT	SUPPORT	LAGER	SOPORTE
15	039.062	1	SUPPORTO RULLO EL100	SUPPORT	SUPPORT	LAGER	SOPORTE
16	20.0.0.10050	1	VITE	SCREW	VIS	SCHRAUBE	TORNILLO
17	20.0.0.10035	6	VITE	SCREW	VIS	SCHRAUBE	TORNILLO
18	15.1.0.00.010	3	RONDELLA	WASHER	RONDELLE	SCHEIBE	ARANDELA
19	071.035	2	BOCCOLA SUPPORTO RULLO	ROLLER BUSHING	COUSSINET ROULEAU	BUCHSE WALZE	CONJINETE RODILLO
20	000.068	1	REGISTRO	ADJUSTER	REGLAGE	REGULATOR	AJUSTE
21	61.00.00204	2	SUPPORTO	SUPPORT	SUPPORT	LAGER	SOPORTE
22	15.2.1.00.008	8	RONDELLA DENTELLATA	SERRATED WASHER	RONDELLE EVENTAIL	FÄCHERSCHEIBE	ARANDELA ABANICO
23	039.040	1	RULLO EL50	ROLLER	ROULEAU	WALZE ROLLE	RODILLO
23	071.010	1	RULLO EL75	ROLLER	ROULEAU	WALZE ROLLE	RODILLO
23	039.060	1	RULLO EL100	ROLLER	ROULEAU	WALZE ROLLE	RODILLO
24	039.043	1	PULISCI RULLO EL50	ROLLER CLEANER	NETTOYEUR ROULEAU	WALZENREINIGER	LIMPIADOR RODILLO
24	039.032	1	PULISCI RULLO EL75	ROLLER CLEANER	NETTOYEUR ROULEAU	WALZENREINIGER	LIMPIADOR RODILLO



EL 50-75-100 SH

Tav. 07.0



GRUPPO TELAIO E RULLO (EL 50-75-100 SH)
FRAME AND ROLLER GROUP (EL 50-75-100 SH)
GROUPE CHASSIS ET ROULEAU (EL 50-75-100 SH)
GRUPPE RAHMEN UND WALZEN (EL 50-75-100 SH)
GRUPO BASTIDOR Y RODILLO (EL 50-75-100 SH)

EL 50-75-100 SH

Tav. 07.0

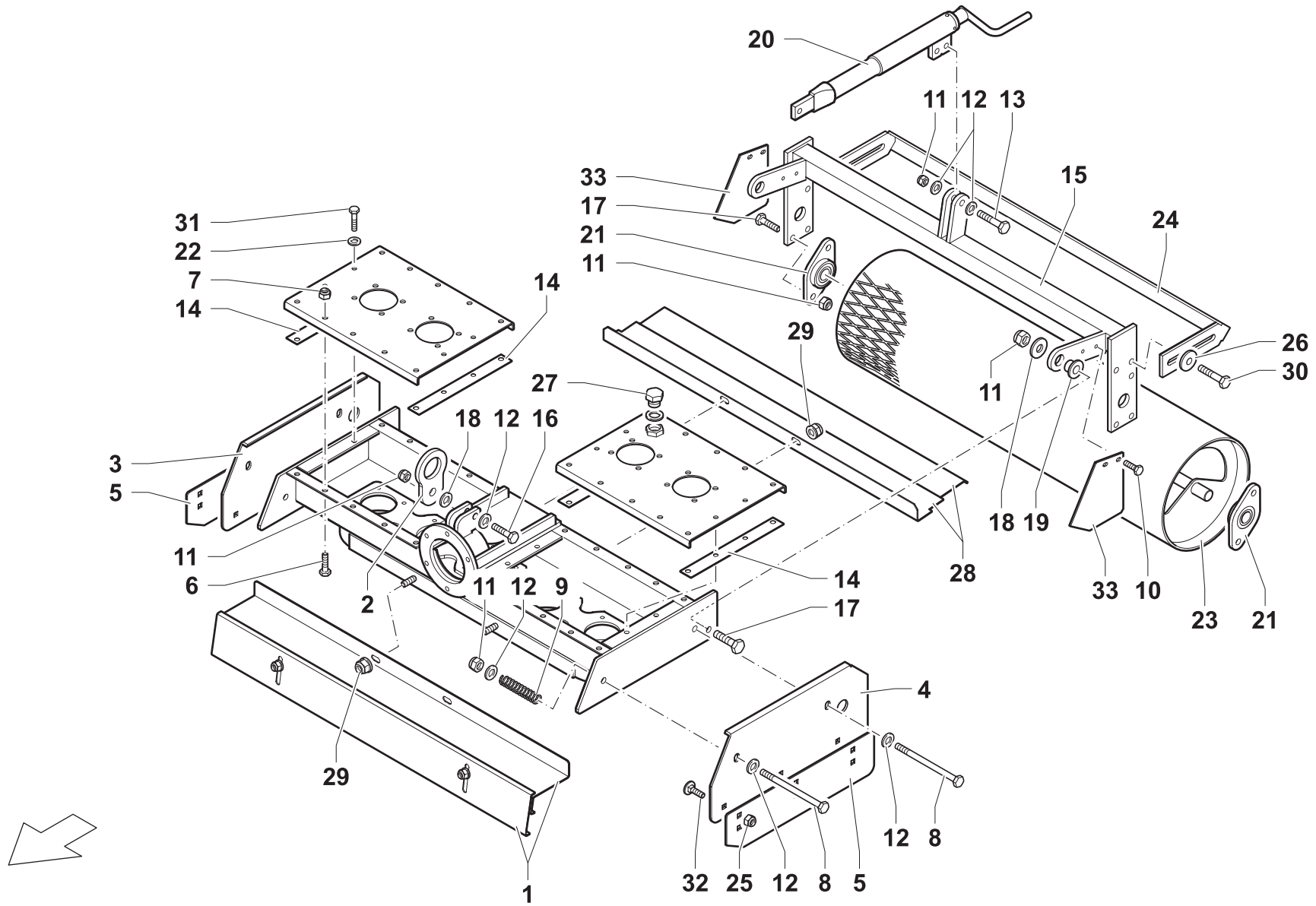

Rif.	CODICE	Qty	Descrizione	Description	Designation	Benennung	Denominaciones
24	039.063	1	PULISCI RULLO EL100	ROLLER CLEANER	NETTOYEUR ROULEAU	WALZENREINIGER	LIMPIADOR RODILLO
25	30.01.00.008	6	DADO AUTOBLOCCANTE	STOP NUT	ECROU DE SURETE	SPERRMUTTER	TUERCA AUTOTRABADORA
26	15.1.0.00.008	4	RONDELLA	WASHER	RONDELLE	SCHEIBE	ARANDELA
27	050.001	1	TAPPO	CAP	BOUCHON	STOPFEN	TAPÓN
28	039.047	1	PROTEZIONE POSTERIORE EL50	REAR GUARD	PROTECTION ARRIÈRE	HINTERE SCHUTZABDECKUNG	PROTECCIÓN POSTERIOR
28	039.039	1	PROTEZIONE POSTERIORE EL75	REAR GUARD	PROTECTION ARRIÈRE	HINTERE SCHUTZABDECKUNG	PROTECCIÓN POSTERIOR
28	039.074	1	PROTEZIONE POSTERIORE EL100	REAR GUARD	PROTECTION ARRIÈRE	HINTERE SCHUTZABDECKUNG	PROTECCIÓN POSTERIOR
29	32.02.00.0.08	4	DADO	NUT	ECROU	MUTTER	TUERCA
30	21.0.0.08016	4	VITE	SCREW	VIS	SCHRAUBE	TORNILLO
31	21.0.1.08020	8	VITE	SCREW	VIS	SCHRAUBE	TORNILLO
32	050.253	6	BULLONE	SCREW	VIS	SCHRAUBE	TORNILLO
33	039.026	2	PROTEZIONE LATERALE	SIDE GUARD	PROTECTION LATERALE	SEITLICHE SCHUTZABDECKUNG	PROTECCIÓN LATERAL



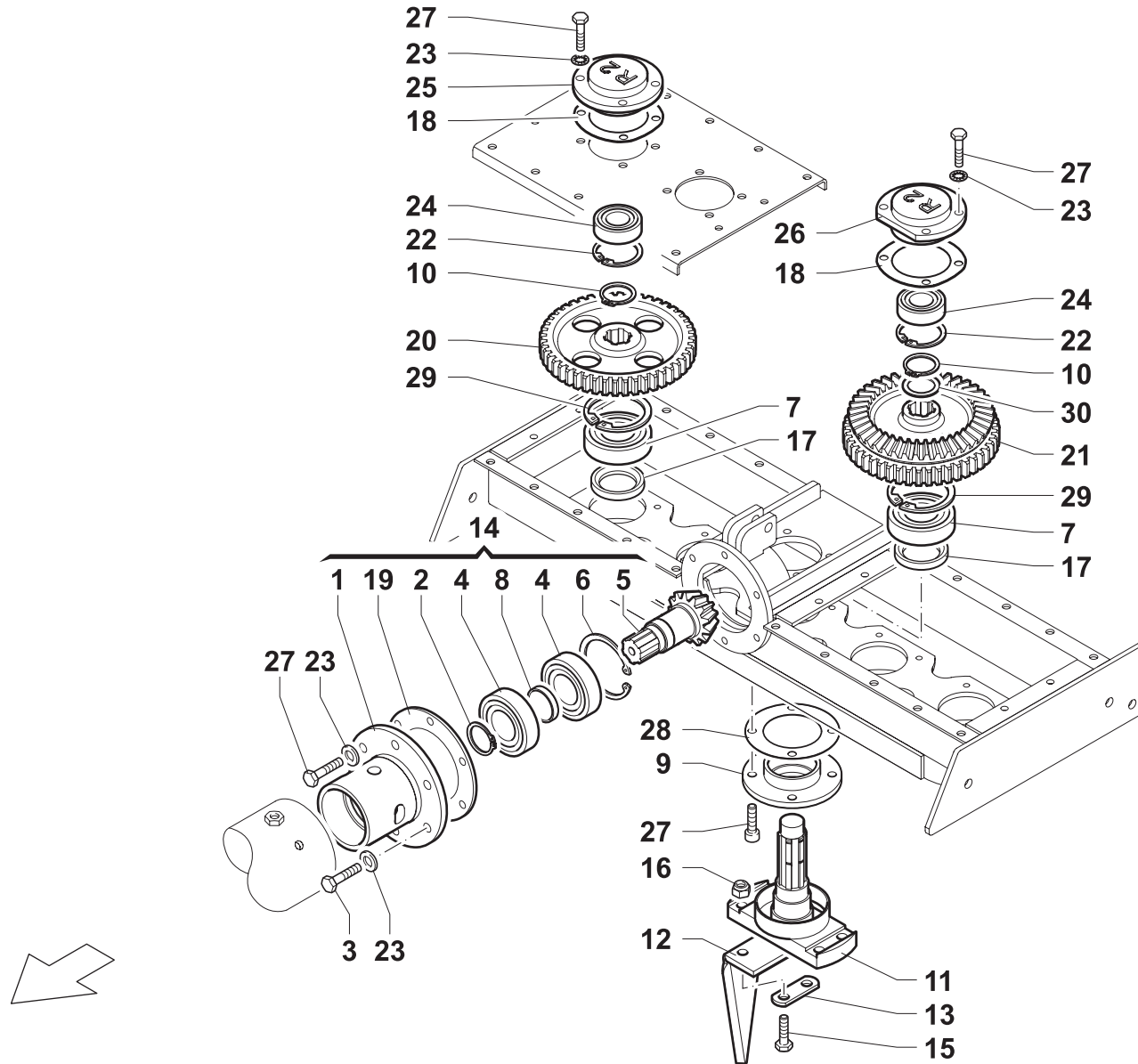

<i>Rif.</i>	<i>CODICE</i>	<i>Qnt</i>	<i>Descrizione</i>	<i>Description</i>	<i>Designation</i>	<i>Benennung</i>	<i>Denominaciones</i>
1	039.019	1	MOZZO	HUB	MOYEU	NABE	CUBO
2	18.01.01.030	1	SEEGER	RING	BAGUE	RING	ANILLO
3	21.0.0.08022	3	VITE	SCREW	VIS	SCHRAUBE	TORNILLO
4	60.02.06006	2	CUSCINETTO	BEARING	PALIER	KUGELLAGER	COJINETE
5	039.004	1	PIGNONE	SPROCKET	PIGNON	RITZEL	PINON
6	18.00.00.055	1	SEEGER	RING	BAGUE	RING	ANILLO
7	60.00.06205	5	CUSCINETTO	BEARING	PALIER	KUGELLAGER	COJINETE
8	031.041	1	DISTANZIALE	SPACER	ENTRETOISE	ABSTANDSHALTER	SEPARADOR
9	039.005	5	FLANGIA	FLANGE	BRIDE	FLANSCH	BRIDA
10	18.01.01.025	5	SEEGER	RING	BAGUE	RING	ANILLO
11	039.002	5	FORCELLA	FORK	FOURCHE	GABEL	HORQUILLA
12	000.021	6	DENTE EL50	TOOTH	DENT	ZAHN	DIENTE
12	000.010	10	DENTE	TOOTH	DENT	ZAHN	DIENTE
13	000.002	10	PIASTRINA	PLATE	PLAQUETTE	PLÄTTCHEN	PLACA
14	039.035	1	MOZZO PIGNONE COMPLETO	COMPLETE HUB WITH SPROCKET	MOYEU COMPLET AVEC PIGNON	KOMPLLETTE NABE MIT ZAHNRAD	CUBO COMPLETO CON PIÑÓN
15	20.1.1.10035	20	VITE	SCREW	VIS	SCHRAUBE	TORNILLO
16	30.03.01.010	20	DADO AUTOBLOCCANTE	STOP NUT	ECROU DE SURETE	SPERRMUTTER	TUERCA AUTOTRABADORA
17	70.1.030477	5	ANELLO TENUTA	SEAL	GARNITURE	DICHTRING	GUARNICIÓN
18	039.015	5	GUARNIZIONE	PACKING	JOINT	DICHTUNG	GUARNICIÓN
19	039.017	1	GUARNIZIONE	PACKING	JOINT	DICHTUNG	GUARNICIÓN
20	039.001	4	INGRANAGGIO	GEAR	ENGRENAGE	ZAHNRADGETRIEBE	ENGRANAJE
21	039.003	1	CORONA	RING GEAR	COURONNE	KRANZ	CORONA
22	18.00.00.042	5	SEEGER	RING	BAGUE	RING	ANILLO
23	15.2.1.00.008	26	RONDELLA DENTELLATA	SERRATED WASHER	RONDELLE EVENTAIL	FÄCHERSCHEIBE	ARANDELA ABANICO
24	60.02.06004	5	CUSCINETTO	BEARING	PALIER	KUGELLAGER	COJINETE
25	039.007	4	COPERCHIETTO LATERALE	SIDE COVER	COUVERCLE LATÉRÀL	KLEINER SEITL. DECKEL	TAPA LATERAL
26	039.006	1	COPERCHIETTO CENTRALE	CENTRAL COVER	COUVERCLE CENTRALE	KLEINER ZENTRALER DECKEL	TAPA CENTRAL
27	21.0.1.08020	43	VITE	SCREW	VIS	SCHRAUBE	TORNILLO
28	039.016	5	GUARNIZIONE	PACKING	JOINT	DICHTUNG	GUARNICIÓN
29	18.00.00.052	5	SEEGER	RING	BAGUE	RING	ANILLO
30	09.050.25035	1	RONDELLA	WASHER	RONDELLE	SCHEIBE	ARANDELA



EL 50-75-100 SH

Tav. 08.0

INDICE DELLE TAVOLE • TABLE INDEX • INDEX DES TABLEAUX

01.0	GRUPPO TELAIO E RULLO (EL 50-75-100 R)	FRAME AND ROLLER GROUP (EL75)	GROUPE CHASSIS ET ROULEAU (EL 50-75-100 R)
02.0	TRASMISSIONE	TRANSMISSION	TRANSMISSION
03.0	RUSPETTA (EL 50-75-100 R)	LEVELLING BAR (EL 50-75-100 R)	BARRE NIVELEUSE (EL 50-75-100 R)
04.0	KIT RULLO A GABBIA (EL75)	CAGE ROLLER KIT (EL75)	KIT ROULEAU A CAGE (EL75)
05.0	KIT RULLO PIENO (EL 50-75)	PLAIN ROLLER KIT (EL 50-75)	KIT ROULEAU PLEIN (EL 50-75)
06.0	KIT RULLO CORTO (EL 50-75-100)	SHORT ROLLER KIT (EL 50-75-100)	KIT ROULEAU COURT (EL 50-75-100)
07.0	GRUPPO TELAIO E RULLO (EL 50-75-100 SH)	FRAME AND ROLLER GROUP (EL 50-75-100 SH)	GROUPE CHASSIS ET ROULEAU (EL 50-75-100 SH)
08.0	TRASMISSIONE (EL75 SH)	TRANSMISSION (EL75 SH)	TRANSMISSION (EL75 SH)

TABELLEN-VERZEICHNIS • INDICE DE LAS TABLAS

01.0	GRUPPE RAHMEN UND WALZEN (EL 50-75-100 R)	GRUPO BASTIDOR Y RODILLO (EL 50-75-100 R)
02.0	TRANSMISSION	TRANSMISIÓN
03.0	PLANIERSTANGE (EL 50-75-100 R)	BARRA NIVELADORA (EL 50-75-100 R)
04.0	KAFIGWALZENKIT (EL75)	KIT RODILLO A JAULA (EL75)
05.0	WOLLWALZENKIT (EL 50-75)	KIT RODILLO LLANO (EL 50-75)
06.0	KIT KURZE WALZE (EL 50-75-100)	KIT RODILLO CORTO (EL 50-75-100)
07.0	GRUPPE RAHMEN UND WALZEN (EL 50-75-100 SH)	GRUPO BASTIDOR Y RODILLO (EL 50-75-100 SH)
08.0	TRANSMISSION (EL75 SH)	TRANSMISIÓN (EL75 SH)

