



MURATORI

**TIPO-TYPE-TYP
MRP1 230**

CATALOGO RICAMBI
Catalogue Pièces Detachées
Ersatzteilkatalog
Spare Parts Catalogue
Catálogo Recambios

EDIZIONE 09/2019

Per ordinare parti di ricambio specificare:

- tipo e matricola della macchina (apposti sulla macchina o sui documenti di acquisto);
- numero del riferimento del pezzo nel disegno (Pos.), numero della tavola (Tav.) e numero di codice

N.B.: le indicazioni destro o sinistro vengono date guardando la macchina da dietro.

Pour les commandes de pièces de rechange veuillez spécifier:

- *type et numéro de série de la machine (indiqués sur la machine et sur le bon d'achat);*
- *numéro de référence du pièce sur le plan (Pos.), numéro du plan (Tav.) et numéro de code (codice)*

N.B.: *les indications droite ou gauche sont données en regardant la machine par derrière.*

Zum Bestellen von Ersatzteilen folgendes angeben:

- *Typ und Serien-Nr. der Maschine (zu finden auf der Maschine oder der Einkaufspapieren);*
- *Bezug-Nr. des Ersatzteils auf der Zeichnung (Pos.), Zeichnungsnummer (Tav.) und Kodenummer (codice)*

N.B.: *Die Angaben rechts und links verstehen sich so, dass man hinter der Maschine steht.*

When ordering spare parts specify:

- machine type and serial number (found on the machine or on the purchasing documents);
- reference number of the part on the relative drawing (Pos.) number of the drawing (Tav.) and part number (codice)

N.B.: right-hand or left-hand indications are made by viewing the machine from the rear.

TAV. 1.0

GRUPPO TELAIO
 ENSEMBLE CHASSIS
 SATZ FÜR RAHMEN
 KIT FOR FRAME

TAV. 2.0

TRASMISSIONE ROTORI
 ROTORS TRANSMISSION
 ROTOREN ANTRIEB
 TRANSMISSION ROTORS

TAV. 3.0

GRUPPO MOLTIPLICATORE
 ENSEMBLE MULTIPLICATEUR
 SATZ FÜR GETRIEBE
 KIT FOR GEAR BOX

TAV. 4.0

INGRASSATORI ESTERNI
 GRAISSAGE CENTRALISE
 SAMMELSCHMIERUNG
 GREASE EXTENSIONS

TAV. 5.0

RUOTINO ANTISCALPO
 ROULEAU ANTICHOE
 GEGENSTOSSIGE ROLLE
 ANTISCALPING ROLLER

TAV. 6.0

VERSIONE "MULCHING"
 VERSION "MULCHING"
 "MULCHING" VERSION
 "MULCHING" VERSION

TAV. 7.0

RUOTE PNEUMATICHE
 ROUES PNEUMATIQUES
 PNEURÄDER
 TYRE WHEELS

TAV. 8.0

ATTACCO FRONTALE STANDARD
 ATTELAGE FRONTAL
 FRONTANBAU
 FRONT LINKAGE

TAV. 9.0

ALBERO CARDANICO COMPLETO
 ARBRE A JOINTS DE CARDAN
 KARDANWELLE
 PTO SHAFT

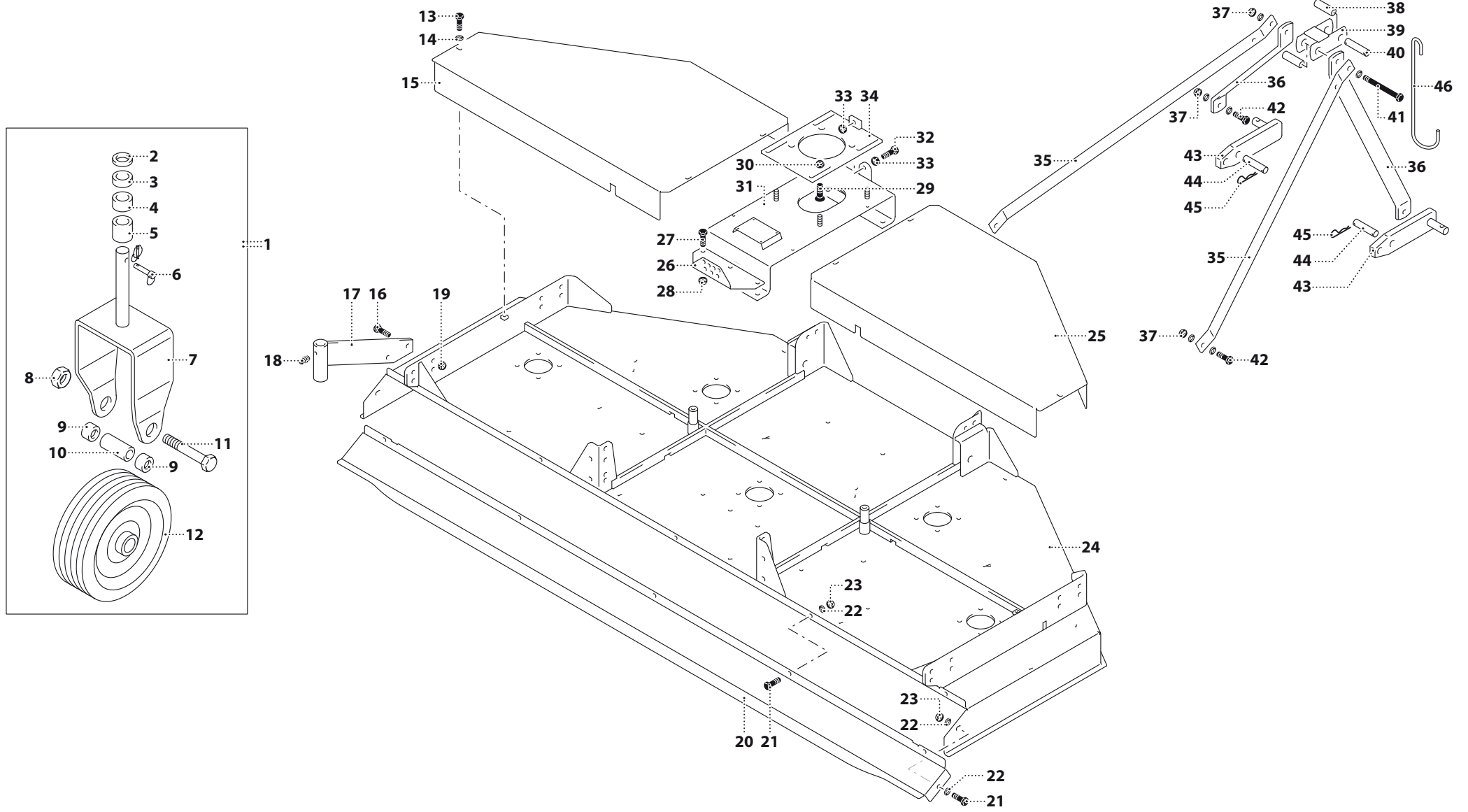

MURATORI MRP1 230

TAV. 1.0

POS.	N° CODICE	Q.	DESCRIZIONE	DESIGNATION	BENENNUNG	DESCRIPTION	DESIGNAZIONE	Da matr. De nr. serie Vom Seriennr. From serial nr.	Fino matr. Jusqu'au nr. serie Bis Seriennr. Up to serial nr.
1	45166800		RUOTA COMPLETA	ENSEMBLE ROUE	SATZ RAD	WHEEL ASSEMBLY			
2	32174600		SPESSORE	EPAISSEUR	BEILAGERING	SPACER	H = 6		
3	32174700		SPESSORE	EPAISSEUR	BEILAGERING	SPACER	H = 12		
4	32174900		SPESSORE	EPAISSEUR	BEILAGERING	SPACER	H = 24		
5	32175000		SPESSORE	EPAISSEUR	BEILAGERING	SPACER	H = 32		
6	64004800		SPINA	GOUPILLE	STIFT	PIN	Ø 8		
7	40234300		FORCELLA	FOURCHE	GABEL	YOKE			
8	62010600		DADO	ECROU	MUTTER	NUT			
9	32174900		SPESSORE	EPAISSEUR	BEILAGERING	SPACER	H = 24		
10	38023500		BOCCOLA	DOUILLE	BUECHSE	BUSHING			
11	60033000		VITE	VIS	SCHRAUBE	SCREW	TE 12 x 130 UNI 5737		
12	68087600		RUOTA	ROUE	RAD	WHEEL			
13	60015100	6	VITE	VIS	SCHRAUBE	SCREW	TE 8 x 16 UNI 5739		
14	61004700	6	RONDELLA	RONDELLE	SCHEIBE	WASHER	PIANA Ø 8 UNI 6592		
15	39351800	1	CARTER SX	CARTER (G)	SCHUTZABDECKUNG (L)	CASING (LH)			
16	60028200	8	VITE	VIS	SCHRAUBE	SCREW	TE 12 x 40 UNI 5739		
17	40234200	4	STAFFA	BRIDE	BUEGEL	BRACKET			
18	64000200	4	INGRASSATORE	GRAISSEUR	SCHMIERNIPPEL	GREASE FITTING	M 6 x 1 DIRITTO		
19	62010600	8	DADO	ECROU	MUTTER	NUT	M 12 x 1.75 AUTOBLOCC.		
20	39350800	1	CONVOGLIATORE	CONVOYEUR	LEITBLECH	CONVEYOR			
21	60021600	7	VITE	VIS	SCHRAUBE	SCREW	TE 10 x 20 UNI 5739		
22	61004900	2	RONDELLA	RONDELLE	SCHEIBE	WASHER	PIANA Ø 10 UNI 6592		
23	62010400	7	DADO	ECROU	MUTTER	NUT	M 10 x 1.5 AUTOBLOCC.		
24	41133300	1	TELAIO	CHASSIS	RAHMEN	FRAME			
25	39351900	1	CARTER DX	CARTER (D)	SCHUTZABDECKUNG (R)	CASING (RH)			
26	39351700	1	SUPPORTO	SUPPORT	HALTERUNG	SUPPORT			

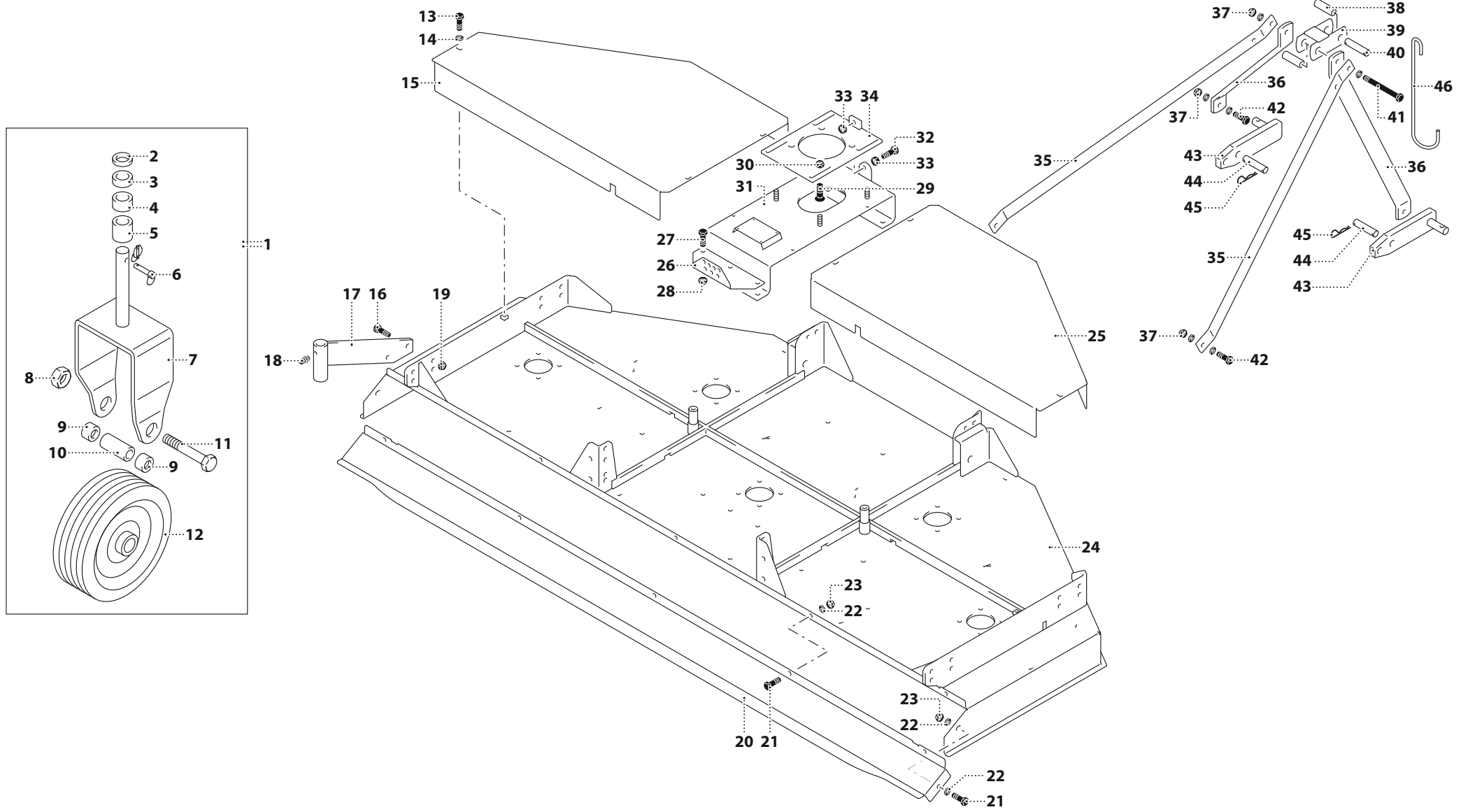

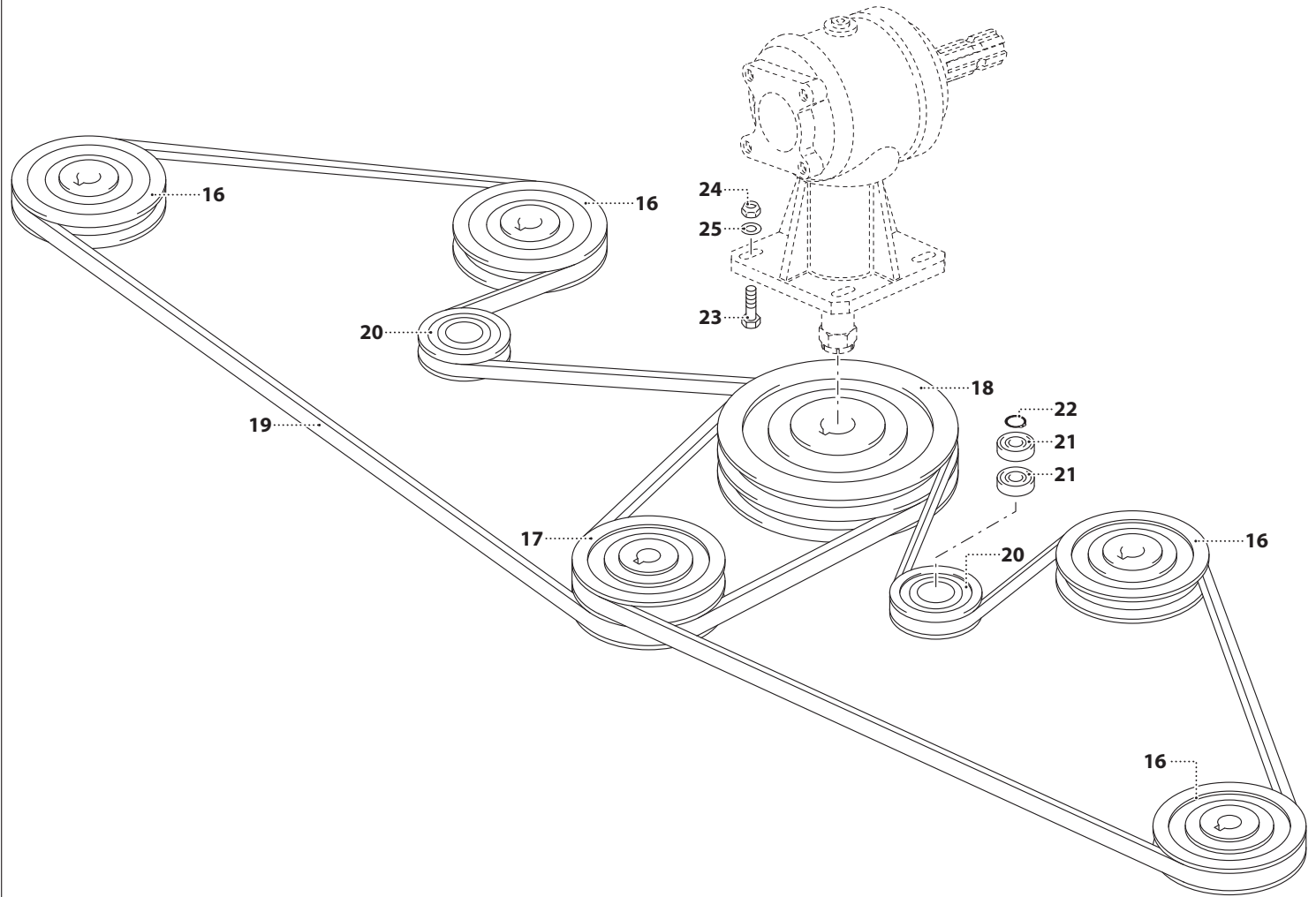
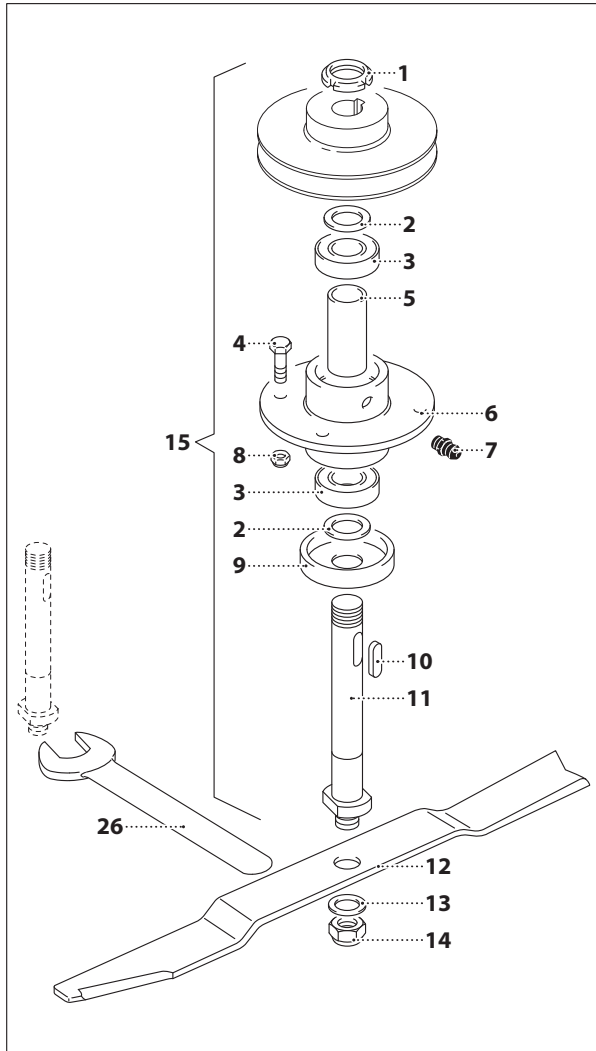

MURATORI MRP1 230

TAV. 2.0

POS.	N° CODICE	Q.	DESCRIZIONE	DESIGNATION	BENENNUNG	DESCRIPTION	DESIGNAZIONE	Da matr. De nr. serie Vom Seriennr. From serial nr.	Fino matr. Jusqu'au nr. serie Bis Seriennr. Up to serial nr.
1	62001200	1	GHIERA	FRETTE	NUTMUTTER	RING NUT	M 25 x 1.5 AUTOBLOCC.		
2	32174100	2	SPESSORE	EPAISSEUR	BEILAGERING	SPACER			
3	67016600	2	CUSCINETTO	ROULEMENT	LAGER	BEARING	6205 RS		
4	60021300	4	VITE	VIS	SCHRAUBE	SCREW	TE 10 x 30 UNI 5739 8.8 ZNT		
5	32174000	1	DISTANZIALE	ENTRETOISE	DISTANZSTÜCK	SPACER			
6	40234100	1	SUPPORTO	SUPPORT	HALTERUNG	SUPPORT			
7	64001800	1	INGRASSATORE	GRAISSEUR	SCHMIERNIPPEL	GREASE FITTING	M 10 x 1 DIRITTO		
8	62010400	4	DADO	ECROU	MUTTER	NUT	M 10 x 1.5 AUTOBLOCC.		
9	39261100	1	PROTEZIONE	PROTECTION	SCHUTZ	GUARD			
10	65001100	1	LINGUETTA	CLAVETTE	FEDER	KEY	8 x 7 x 30 UNI 6604		
11	31078600	1	ALBERO	ARBRE	WELLE	SHAFT			
12	12017800	1	LAMA	LAME DE COUPE	MESSER	BLADE	150		
13	39077800	1	RONDELLA	RONDELLE	SCHEIBE	WASHER	PIANA Øi 19 Øe 50 SP5		
14	62011100	1	DADO	ECROU	MUTTER	NUT	M 18 x 1.5 AUTOBLOCC.		
15	45115100		MOZZO COMPLETO	ENSEMBLE MOYEU	SATZ NABE	SPINDLE ASSEMBLY			
16	68086700	4	PULEGGIA	POULIE	RIEMENSCHLEIBE	PULLEY			
17	68086500	1	PULEGGIA	POULIE	RIEMENSCHLEIBE	PULLEY			
18	68129600	1	PULEGGIA	POULIE	RIEMENSCHLEIBE	PULLEY			
19	68092300	2	CINGHIA	COURROIE	KEILRIEMEN	BELT	B120		
20	68099600	2	PULEGGIA	POULIE	RIEMENSCHLEIBE	PULLEY			
21	67016600	4	CUSCINETTO	ROULEMENT	LAGER	BEARING	6205 RS		
22	63002200	2	ANELLO ELASTICO	ARRETOIR	SPANNRING	SNAP-RING	Ø25 E		
23	60033200	4	VITE	VIS	SCHRAUBE	SCREW	TSEI 16 x 45 UNI 5933		
24	62009000	8	DADO	ECROU	MUTTER	NUT	M 16 x 2 UNI 5589		
25	61006400	4	RONDELLA ELASTICA	RONDELLE A RESSORT	FEDERRING	LICKWASHER	Ø16 UNI 1751		
26	81000100	1	CHIAVE	CLE	SCHLUESSEL	KEY			

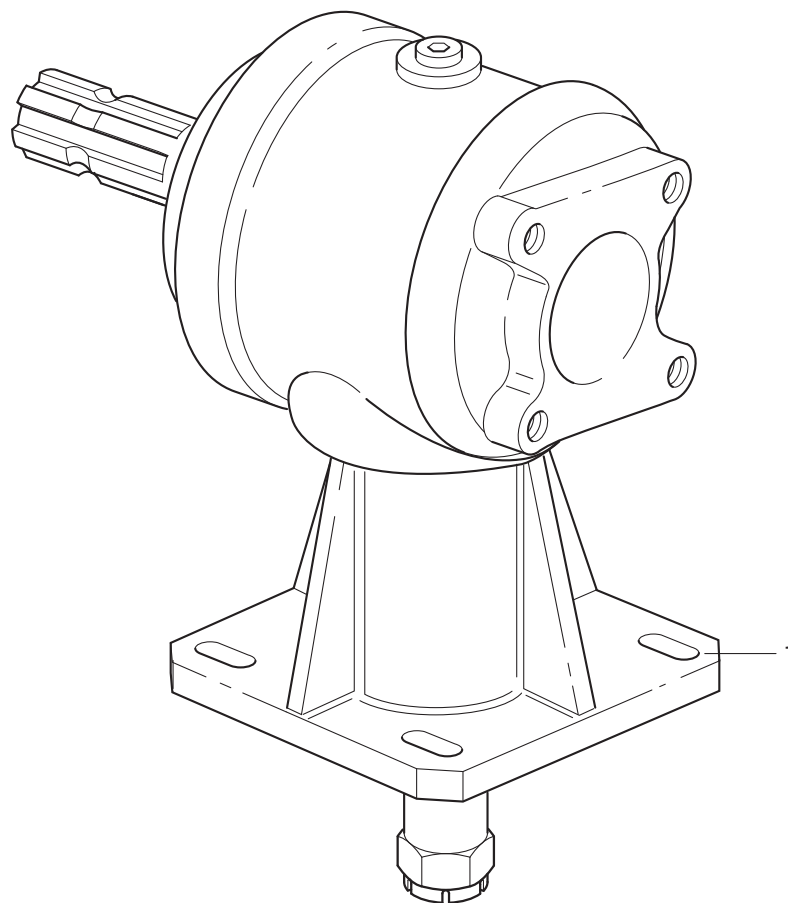

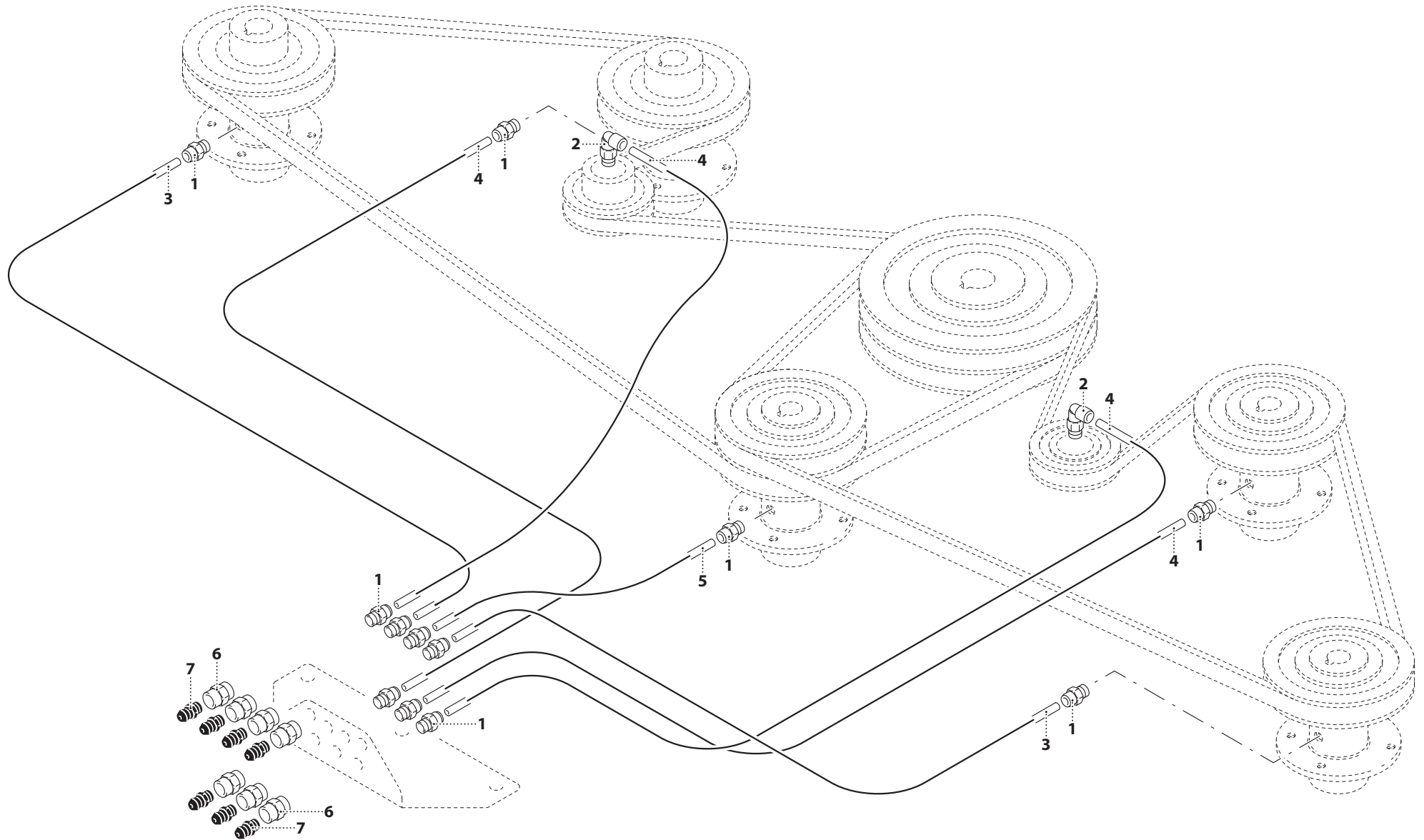

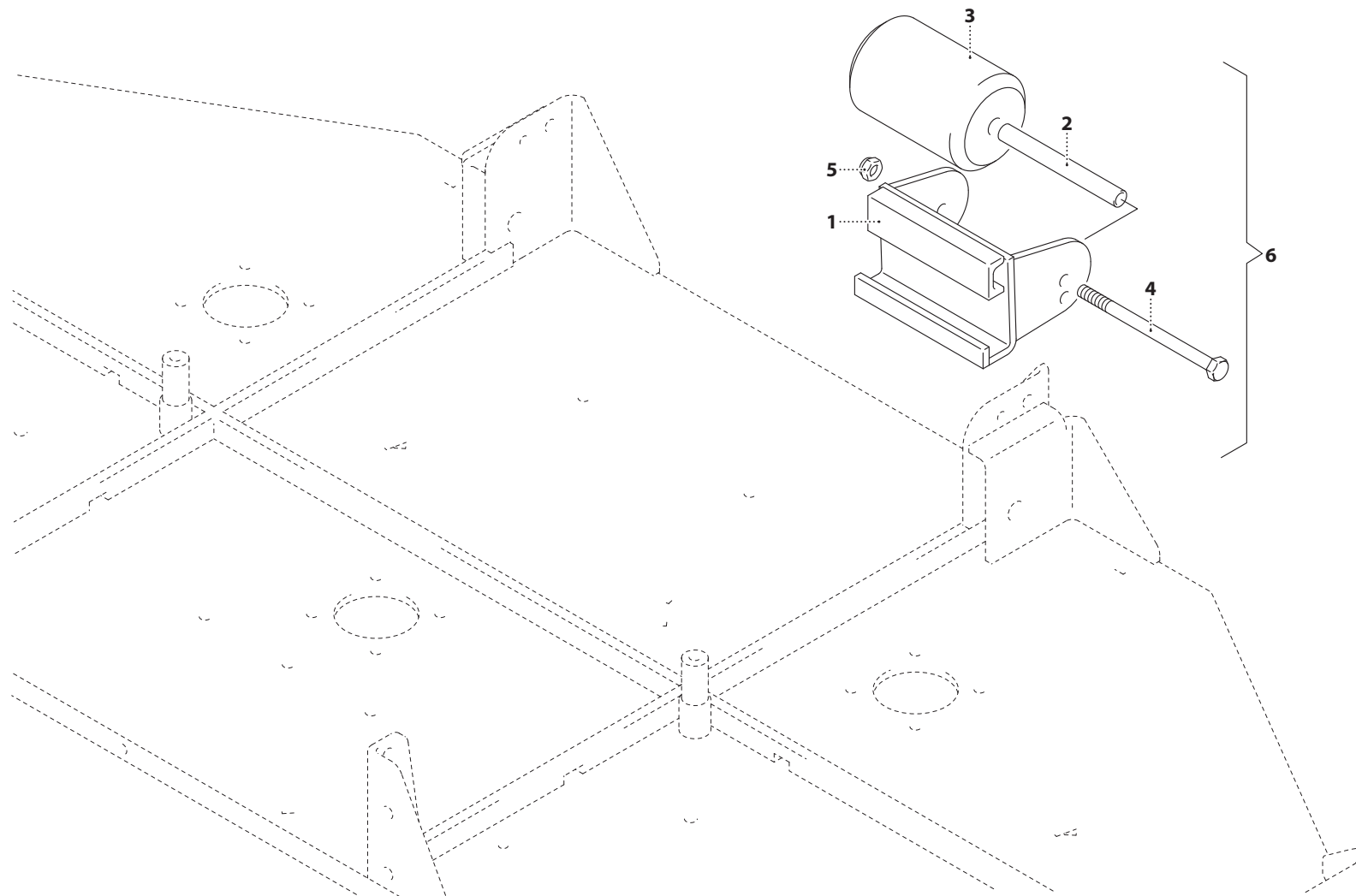

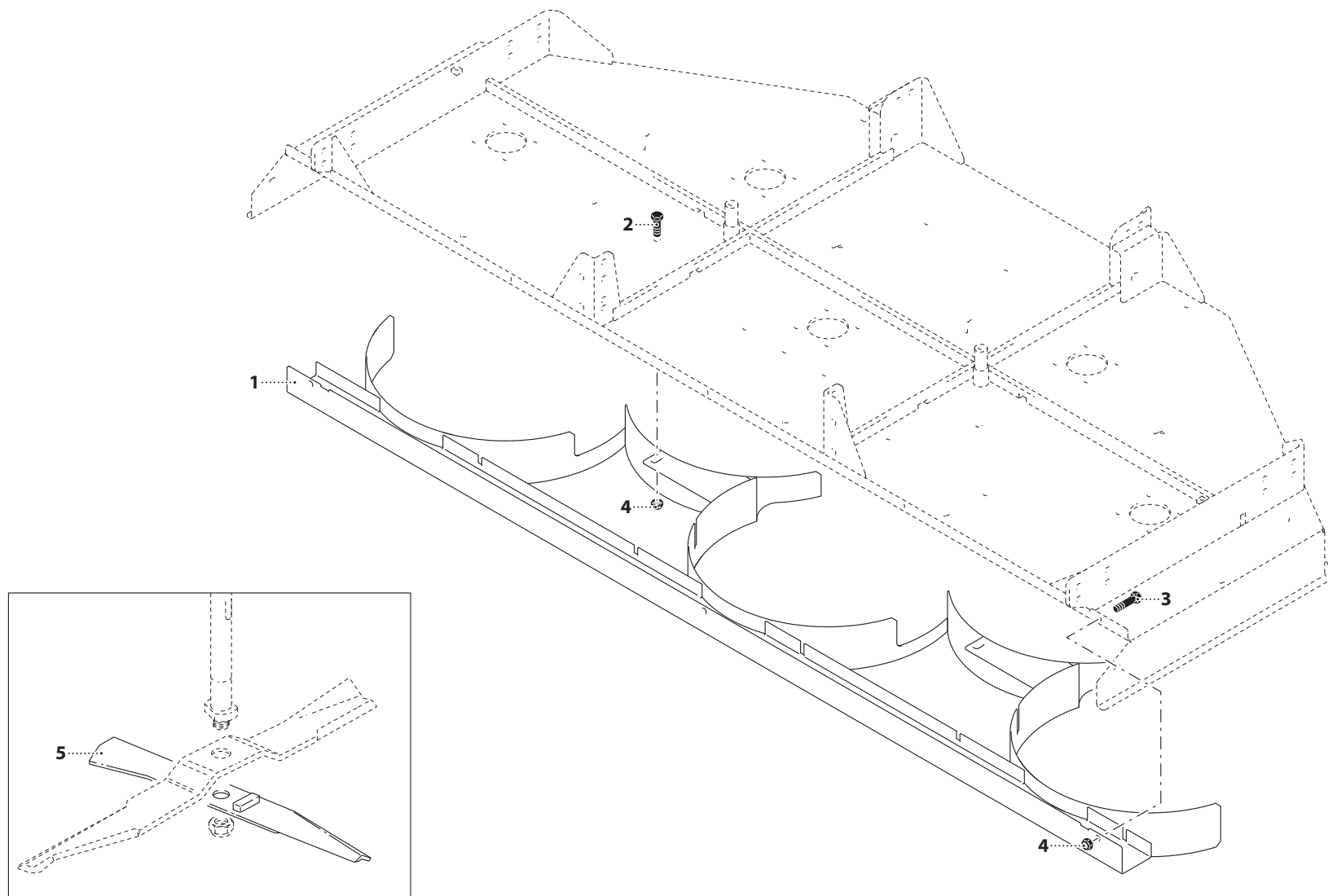

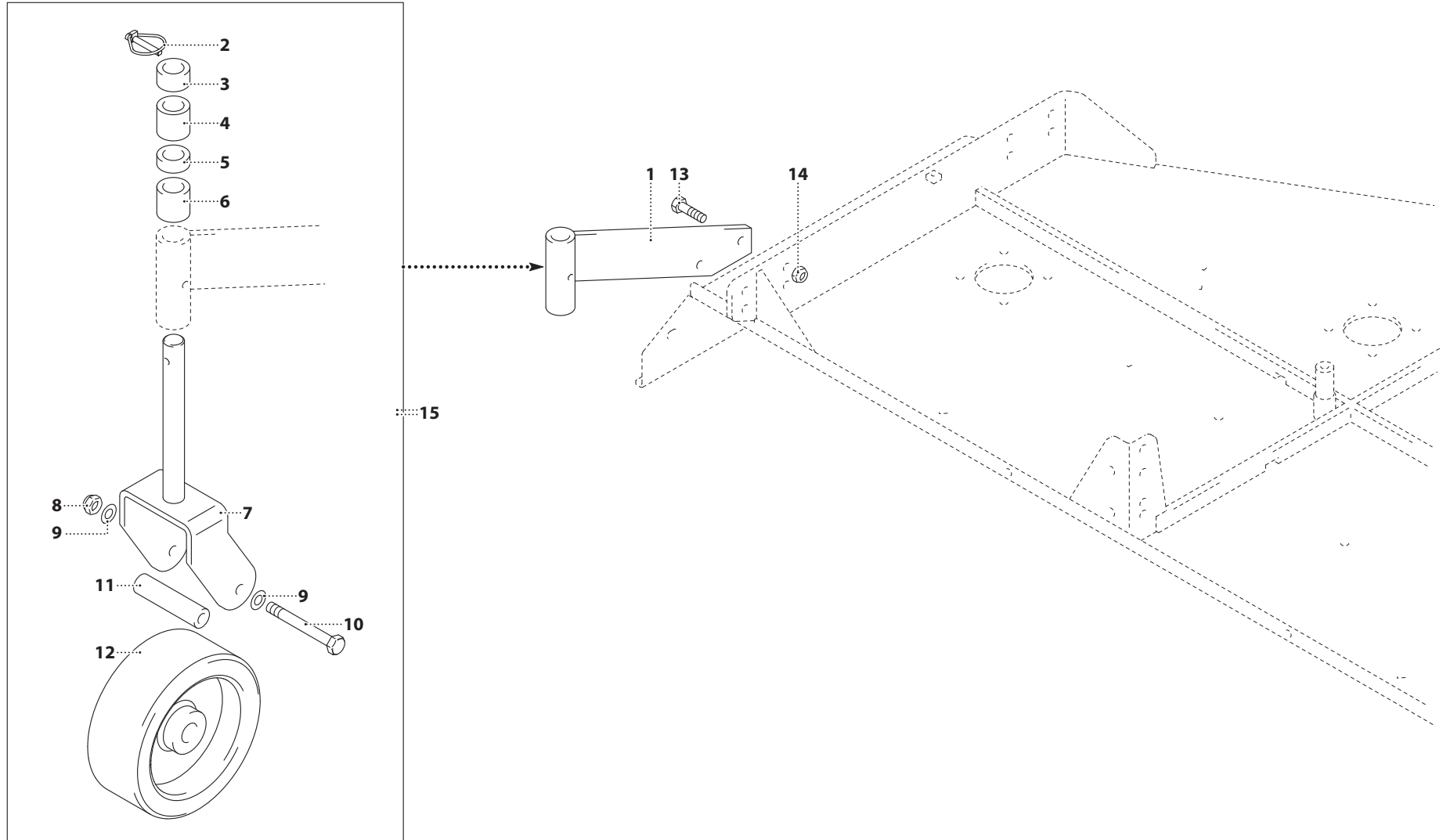

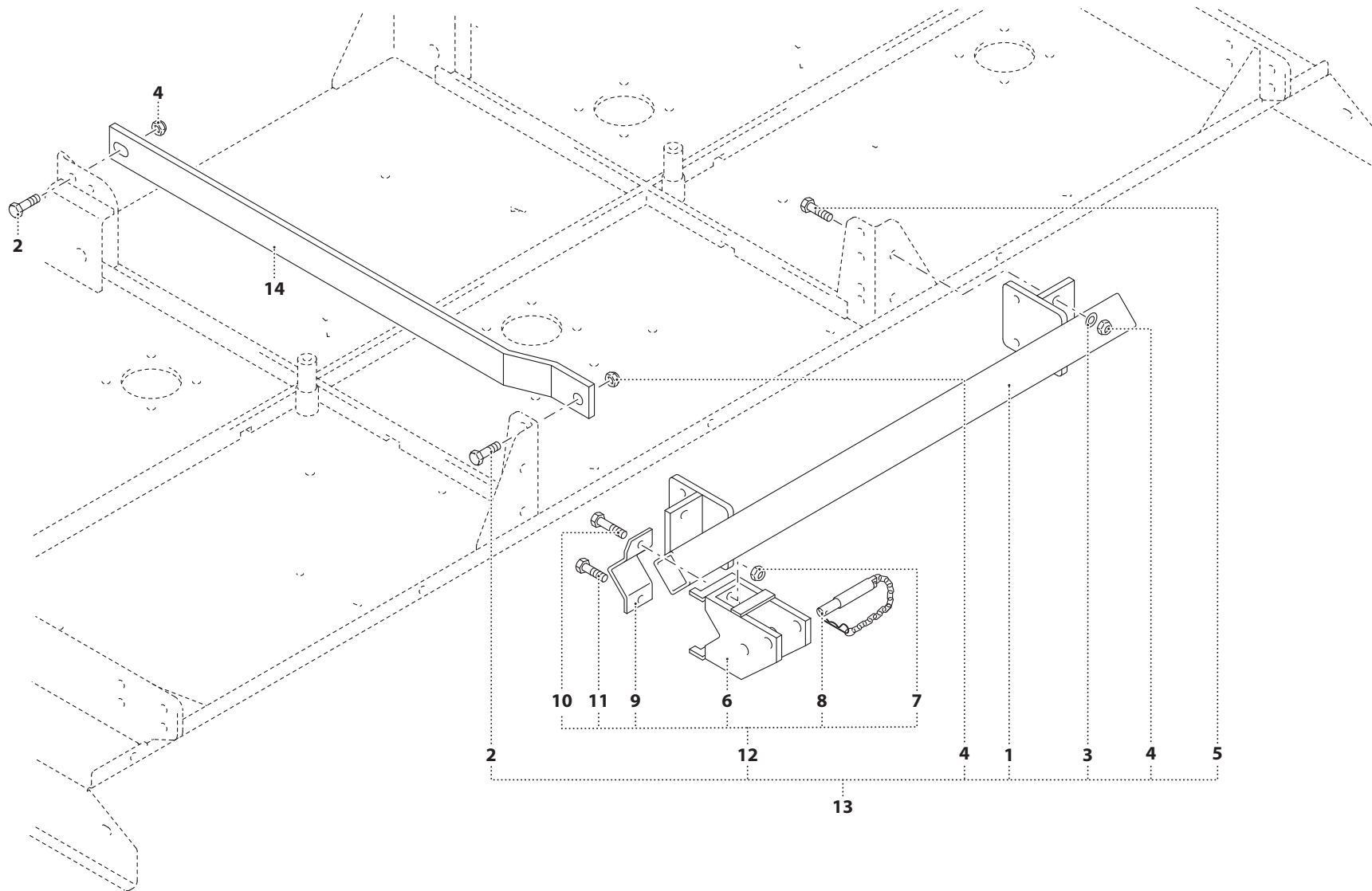

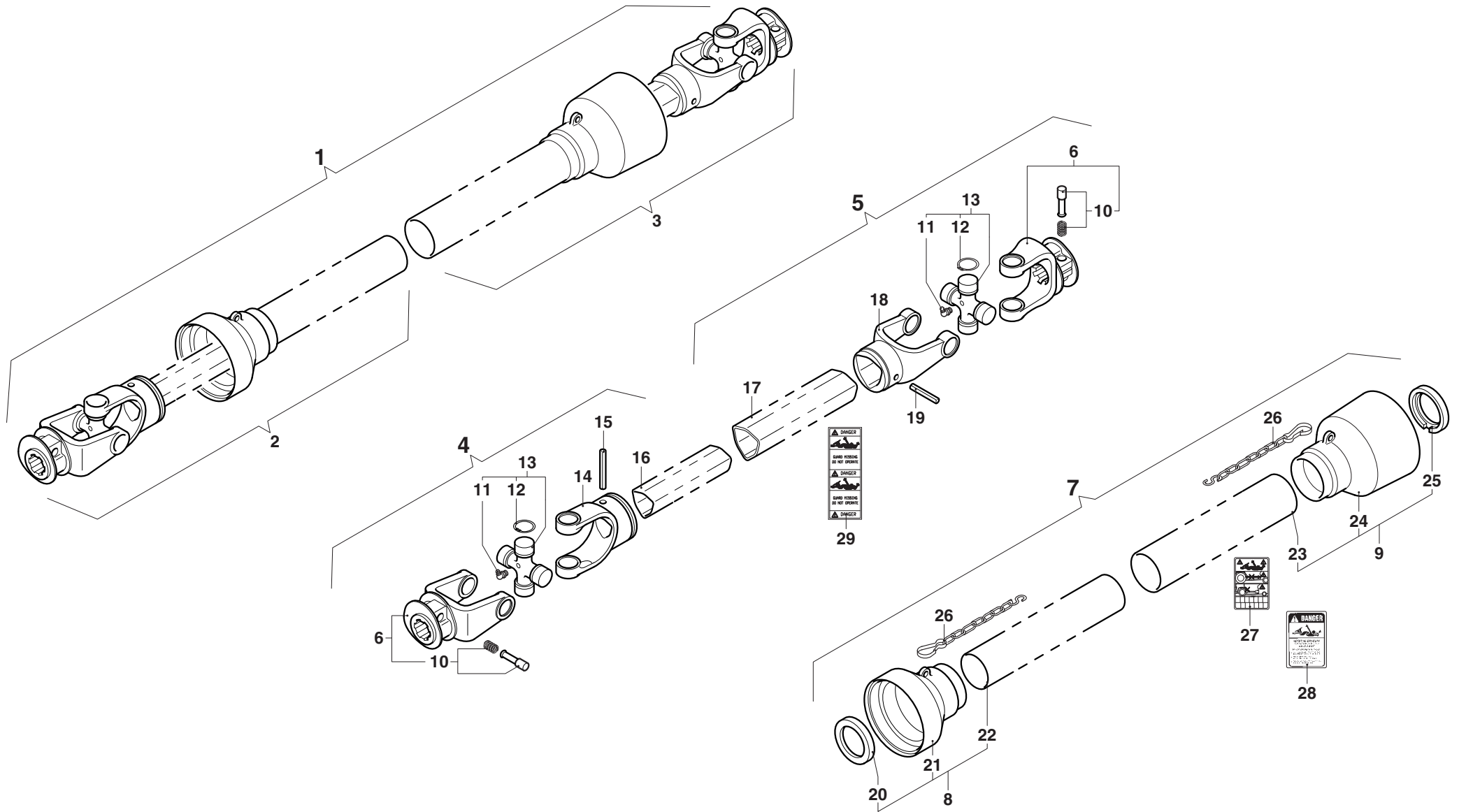

MURATORI MRP1 230

TAV. 9.0

POS.	N° CODICE	Q.	DESCRIZIONE	DESIGNATION	BENENNUNG	DESCRIPTION	DESIGNAZIONE	Da matr. De nr. serie Vom Seriennr. From serial nr.	Fino matr. Jusqu'au nr. serie Bis Seriennr. Up to serial nr.
1	AB408SFDO	1	ALBERO CARDANICO COMPLETO	ARBRE A JOINTS DE CARDAN	KARDANWELLE	PTO SHAFT			
2	B4080B1	1	SEMIALBERO INTERNO	DEMI-ARBRE INTERIEUR	INNENHALBWELLE	INTERNAL HALF SHAFT			
3	B4080B2	1	SEMIALBERO ESTERNO	DEMI-ARBRE EXTERIEUR	AUSSENHALBWELLE	EXTERNAL HALF SHAFT			
4	B408001	1	SEMIALBERO INTERNO	DEMI-ARBRE INTERIEUR	INNENHALBWELLE	INTERNAL HALF SHAFT			
5	B408002	1	SEMIALBERO ESTERNO	DEMI-ARBRE EXTERIEUR	AUSSENHALBWELLE	EXTERNAL HALF SHAFT			
6	0800403	2	FORCELLA	FOURCHE	GABEL	YOKE			
7	083B04080	1	PROTEZIONE	PROTECTION	SCHUTZ	GUARD			
8	083B040801	1	PROTEZIONE INTERNA	PROTECTION INTERIEURE	INNENSCHUTZ	INTERNAL GUARD			
9	083B040802	1	PROTEZIONE ESTERNA	PROTECTION EXTERIEURE	AUSSENSCHUTZ	EXTERNAL GUARD			
10	0986014047	2	PULSANTE	BOUTON	DRUCKKNOPF	PUSH BOTTON			
11	09840081002	2	INGRASSATORE	GRAISSEUR	SCHMIERNIPPEL	GREASE FITTING			
12	09802027	8	ANELLO ELASTICO	ARRETOIR	SPANNRING	SNAP-RING			
13	08204	2	CROCIERA	CROISILLON	KREUZSTUECK	SPIDER			
14	08004011	1	FORCELLA	FOURCHE	GABEL	YOKE			
15	098700855	1	SPINA ELASTICA	GOUPILLE ELASTIQUE	SPANNSTIFT	ELASTIC PIN			
16	09881364100	1	TUBO INTERNO	TUBE INTERIEUR	INNENROHR	INTERNAL TUBE			
17	09881433100	1	TUBO ESTERNO	TUBE EXTERIEUR	AUSSENROHR	EXTERNAL TUBE			
18	08004021	1	FORCELLA	FOURCHE	GABEL	YOKE			
19	098700860	1	SPINA ELASTICA	GOUPILLE ELASTIQUE	SPANNSTIFT	ELASTIC PIN			
20	0265240008	1	GHIERA	FRETTE	NUTMUTTER	RING NUT			
21	0256040425	1	CUFFIA	CAPOUCHON	HAUBE	GUARD			
22	0988961B4080	1	TUBO INTERNO	TUBE INTERIEUR	INNENROHR	INTERNAL TUBE			
23	0988966B4080	1	TUBO ESTERNO	TUBE EXTERIEUR	AUSSENROHR	EXTERNAL TUBE			
24	0256040424	1	CUFFIA	CAPOUCHON	HAUBE	GUARD			
25	0265240007	1	GHIERA	FRETTE	NUTMUTTER	RING NUT			

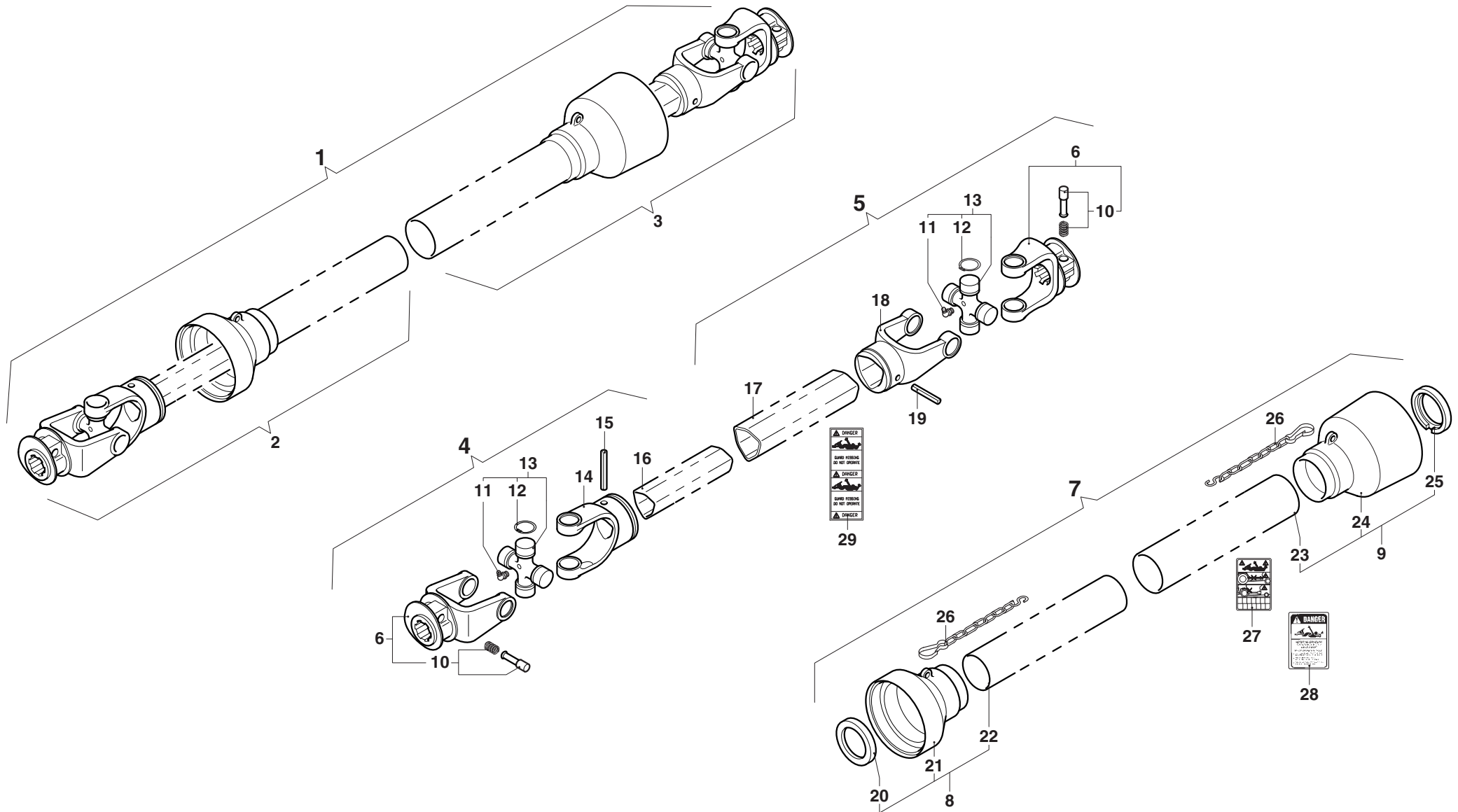



MURATORI S.p.A.

Via Pavarello, 21 - 41051 Castelnuovo Rangone (MO) Italy - Tel. 059.5330611 Fax 059.537259

www.muratoriequip.it *info@muratoriequip.it*

Capitale sociale Euro 480.000 interamente versato

Registro Imprese di Modena

Codice fiscale e numero d'iscrizione: 00708860366